



شركة المصنع السعودي القبرصي لسبك وتشكيل المعادن المحدودة

SAUDI CYPRUS FOUNDRIES LTD.



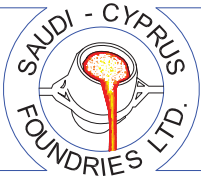
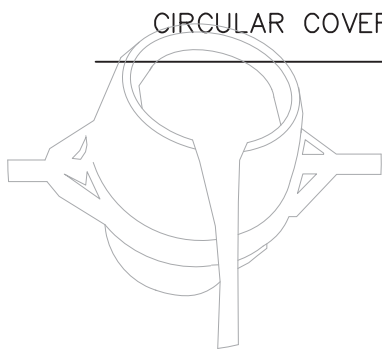
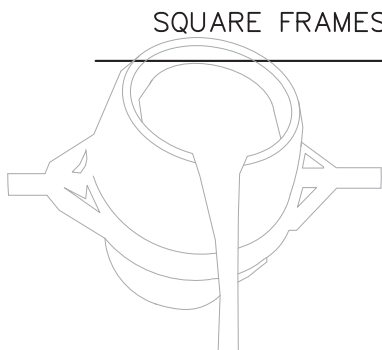

TABLE OF CONTENTS

<i>ITEM</i>	<i>PAGE</i>
INTRODUCTION ARABIC	1.A
INTRODUCTION ENGLISH	1.B

CAST IRON MANHOLE COVERS AND FRAMES

CIRCULAR COVERS AND FRAMES	CLEAR OPENING(mm)	
	MC 1	2
	MC 2	3
	MC 3	4
	MC 4	5
	MC 5	6
	MC 6	7
	MC 7	7
	MC 8	8

SQUARE FRAMES AND CIRCULAR COVER	CLEAR OPENING(mm)	
	SC 1	9
	SC 2	10
	SC 3	11
	SC 4	12
	SC 5	13
	SC 6	13
	SC 7	14
	SC 8	
	SC 9	
	SC 10	
	SC 11	
	SC 12	
	SC 13	

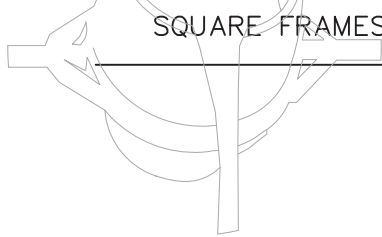
SQUARE FRAMES AND COVERS	CLEAR OPENING(mm)	
	SF 1	15
	SF 2	16
	SF 3	
	SF 4	17
	SF 5	
	SF 6	18
	SF 7	
	SF 8	

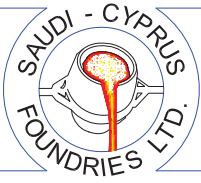

TABLE OF CONTENTS

SQUARE FRAMES AND COVERS	CLEAR OPENING(mm)	PAGE
SF 9	1000sq.	19
SF 10	200sq.	20
SF 11	300sq.	
SF 12	400sq.	
SF 13 RC	600sq.	21
SF 14 RC	600sq.	22
SF 15 RC	600sq.	23
SF 16 RC	700sq.	24
SF 17 RC	800sq.	
RECTANGULAR FRAMES AND COVERS	CLEAR OPENING(mm)	25
RF 1	600x450	26
RF 2	750x600	
RF 3	900x600	27
RF 4	900x600	28
CIRCULAR GRATINGS AND FRAMES	CLEAR OPENING(mm)	29
CG 1	ø280	30
CG 2	ø600	31
SQUARE GRATINGS AND FRAMES	CLEAR OPENING(mm)	32
SG 1	225 sq.	33
SG 2	300sq.	34
SG 3	ø300	35
SG 4	450sq.	36
SG 5	500sq.	37
SG 6	550sq.	38
SG 7	600sq.	39
SG 8	600sq.	40
SG 9	750sq.	41
SG 10	800sq.	
RECTANGULAR GRATINGS AND FRAMES	CLEAR OPENING(mm)	42
RG 1	320x210	43
RG 2	410x300	
RG 3	600x530	44
RG 4	165x750	45
RG 5	215x750	
RG 6	265x750	

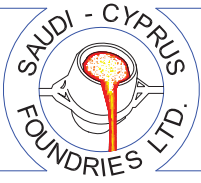

TABLE OF CONTENTS

RECTANGULAR GRATINGS AND FRAMES	CLEAR OPENING(mm)	PAGE	
	RG 7	395x750	46
	RG 8	495x750	
	RG 9	250x750	47
	RG 10	350x750	
	RG 11	195x750	48
	RG 12	295x750	
	RG 13	400x750	49
	RG 14	500x750	
	RG 15	600x750	
	RG 16	1010x450	50
	RG 17	1200x600	51
CAST IRON GARDEN GRATINGS	CLEAR OPENING(mm)	52	
	TG 1	700sq.	53
	TG 2	ø300	54
	TG 3	ø500	55
SURFACE BOX	CLEAR OPENING(mm)	56	
	SB 1	ø120	57
	SB 2	ø140	58
	SB 3	ø200	
	SB 4	ø190	59
	SB 5	ø300	
	SB 6	250sq.	60
DUCTILE IRON CASTINGS	CLEAR OPENING(mm)	61	
	DI 1	ø600	62
	DI 2	ø600	
	DI 3	ø600	63
	DI 4	ø600	
	DI 5	540x290	
CAST METAL STEPS		64	
	ST-AL1		65
	ST-CI2		
	ST-AL3		66
	ST-CI4		

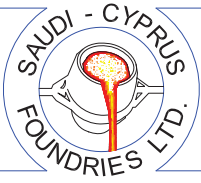
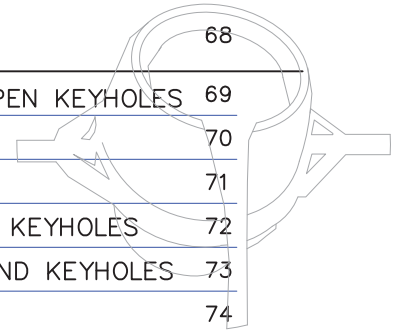
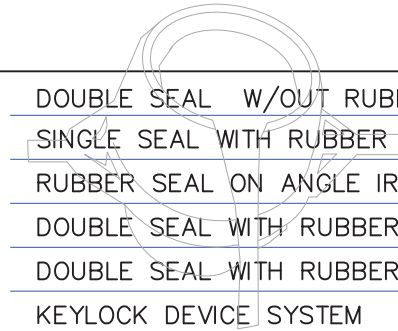
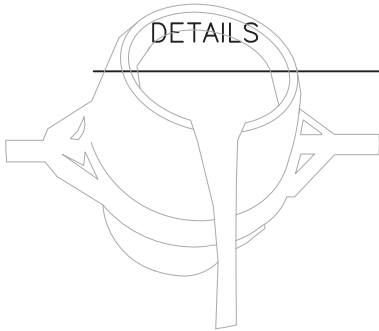

TABLE OF CONTENTS

CAST METAL STEPS	PAGE
ST-AL5	67
ST-CI6	
ST-AL7	
ST-CI8	



DETAILS

68

DOUBLE SEAL W/OUT RUBBER & OPEN KEYHOLES	69
SINGLE SEAL WITH RUBBER	70
RUBBER SEAL ON ANGLE IRON	71
DOUBLE SEAL WITH RUBBER & OPEN KEYHOLES	72
DOUBLE SEAL WITH RUBBER AND BLIND KEYHOLES	73
KEYLOCK DEVICE SYSTEM	74
LOCATION MAP ARABIC	75
LOCATION MAP ENGLISH	76

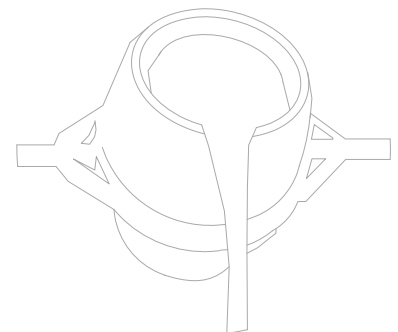
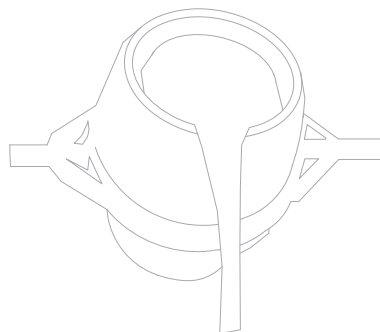
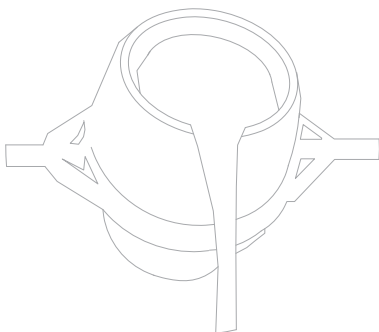
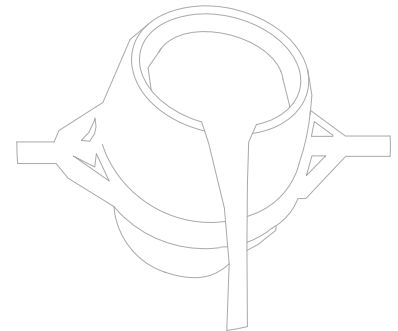
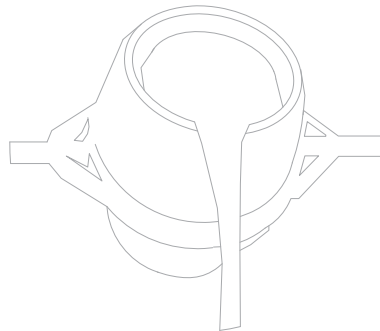
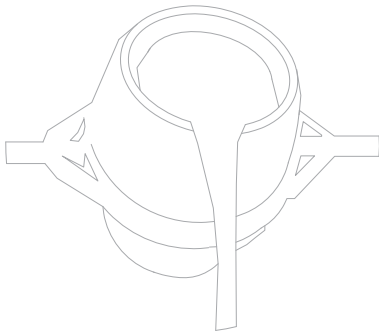



المقدمة

شركة المصنع السعودي القبرصي لسبك و تشكيل المعادن المحدودة لها خبرة طويلة في مجال سبك المعادن وتقديم الحلول المناسبة لآعمال الصرف الصحي والقطع الهندسية لقائمة عملائها التي تشمل البلديات وشركات الكهرباء والاتصالات وشركات المقاولات و أعمال الطرق والمصانع وشركات المصاعد .

تشمل منتجات الشركة اغطية المنهولات وقطع الغيار الصناعية بما يتناسب مع (Ductile)متطلبات العملاء . منتجاتنا مصنعه من الحديد الزهر والحديد المرن الدكتايل والالمنيوم والنحاس والحديد الصلب .

لدينا فريق عمل مكون من مهندسين و اخصائي تسويق ومصممين محترفين لتقديم الخدمات والحلول البديلة للعملاء من مرحلة التصميم حتى اخراج المنتج النهائي طبقاً للمواصفات المطلوبة .

اهدافنا

- تلبية احتياجات السوق من منتجاتنا .
- تقديم افضل الاسعار بجودة عالية .
- التطوير المستمر لكوادر العاملين لتقديم افضل الخدمات للعملاء .



Introduction

Saudi Cyprus Foundries Ltd. has tremendous experience for many years in the casting industry. SCF production is quality controlled and its products provide access and solutions to municipalities, electrical companies highway authorities and telecommunication companies. Services of SCF covers the kingdom of Saudi Arabia, Europe and middle east. At SCF a range of high performance products are manufactured from the following materials: gray iron, ductile iron, steel castings, manganese steel, aluminum and brass. All products manufactured at SCF are in accordance with the prevalent industry standards. Moreover a team of experienced engineers, marketing specialists and designers provide customers with services and solutions from the early stage of designing to the final manufactured product. SCF has the flexibility and capability of achieving the requirements of the customer before and after the sale.

Objectives

- To achieve the market needs of our products
- To present our clients with the best prices while maintaining the best quality.
- To continuously develop our staff in order to present our clients with the best services.

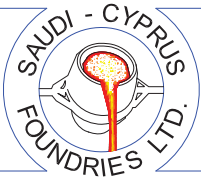

شركة المصنع السعودي القبرصي لسبك و تشكيل المعادن المحدودة
SAUDI CYPRUS FOUNDRIES LTD.



CAST IRON MANHOLE COVERS AND FRAMES

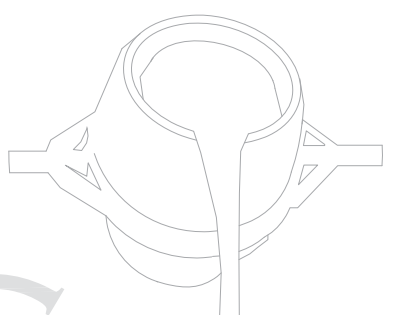

CIRCULAR COVERS AND FRAMES

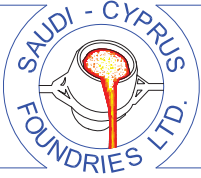

شركة المصنع السعودي القبرصي لسبك و تشكيل المادن المحدودة
SAUDI CYPRUS FOUNDRIES LTD.

ITEM CATEGORY: CAST IRON MANHOLES COVERS AND FRAMES
 ITEM DESCRIPTION: CIRCULAR COVER AND FRAME

Light
 Medium duty cast iron
 Manhole cover and frame.

Features:
 Single seal.
 Blind keyholes.
 Non rotating cover.
 One prising slot.
 Locking device.

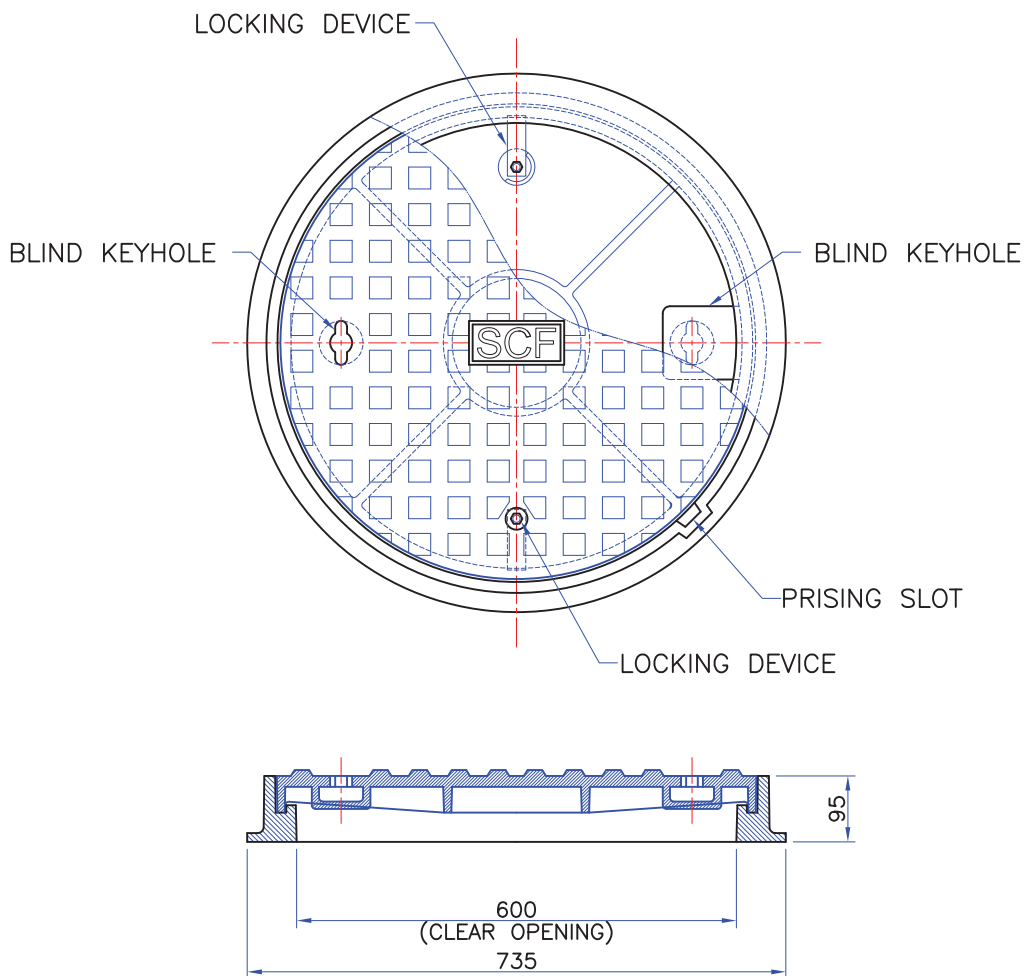

Item code	Clear Opening A(mm)	Over Base B(mm)	Depth C(mm)	Weight (kg)	Loading (Tons)	Standard
MC-1 (LD)	ø600	ø720	90	80	5	EN124
MC-2 (MD)	ø600	ø735	95	98	15	EN124

ALL WEIGHTS ARE SUBJECT TO ± 5%

(IF IN DOUBT, PLEASE ASK)

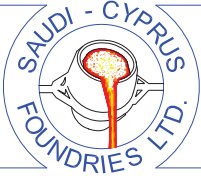

شركة المصنع السعودي القبرصي لسبك و تشكيل المادن المحدودة
SAUDI CYPRUS FOUNDRIES LTD.

ITEM CATEGORY: CAST IRON MANHOLES COVERS AND FRAMES

ITEM DESCRIPTION: CIRCULAR COVER AND FRAME

Medium,
 Heavy duty cast iron
 Manhole cover and frame.

Features:
 Single seal.
 Blind keyholes.
 Non rotating cover.
 One prising slot.
 Locking device.

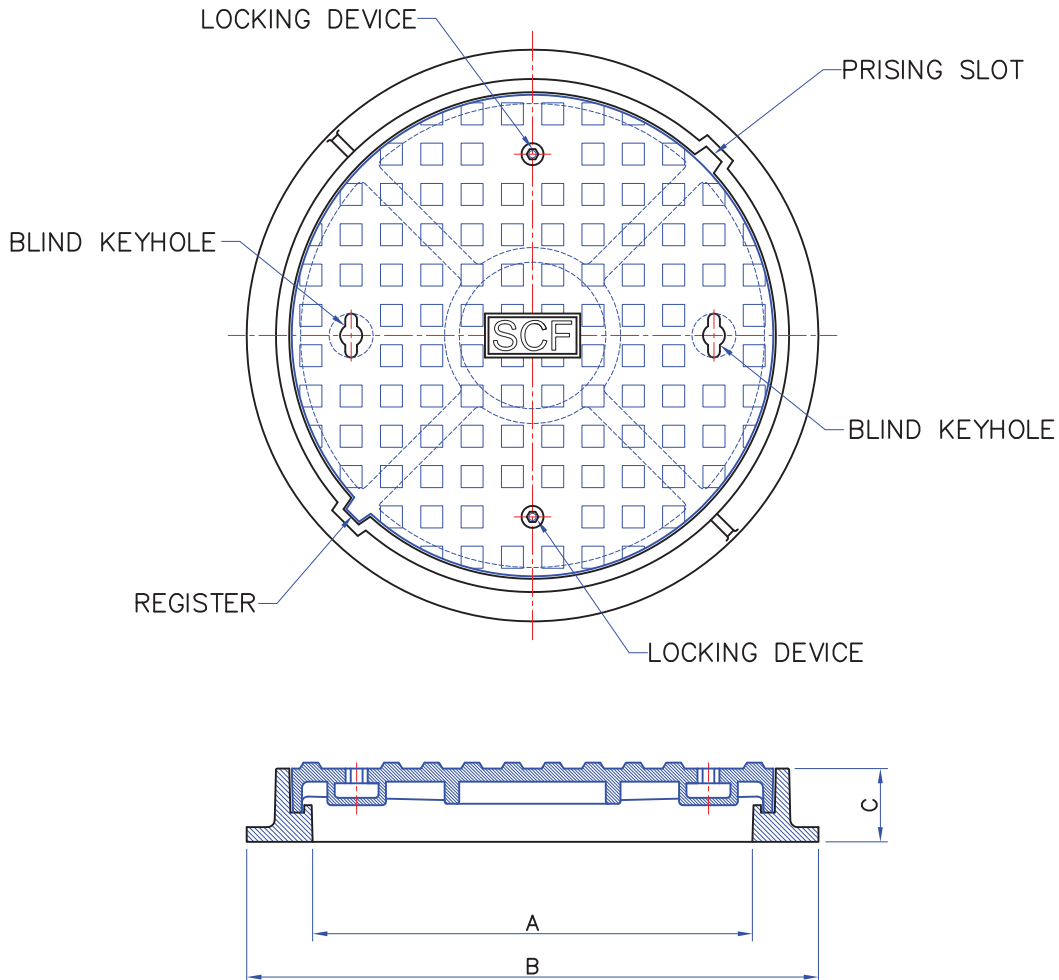

Item code	Clear Opening A(mm)	Over Base B(mm)	Depth C(mm)	Weight (kg)	Loading (Tons)	Standard
MC-3 (MD)	ø600	ø780	100	140	15	EN124
MC-4 (HD)	ø600	ø780	100	160	35	EN124

ALL WEIGHTS ARE SUBJECT TO ± 5%

(IF IN DOUBT, PLEASE ASK)

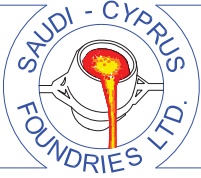

شركة المصنع السعودي القبرصي لسبك و تشكيل المادن المحدودة
SAUDI CYPRUS FOUNDRIES LTD.

ITEM CATEGORY: CAST IRON MANHOLES COVERS AND FRAMES

ITEM DESCRIPTION: CIRCULAR COVER AND FRAME

Heavy duty cast iron
 Manhole cover and frame.

Features:
 Open keyholes.
 Four Air Vent Holes.
 Non rotating cover.
 Two prising slots.

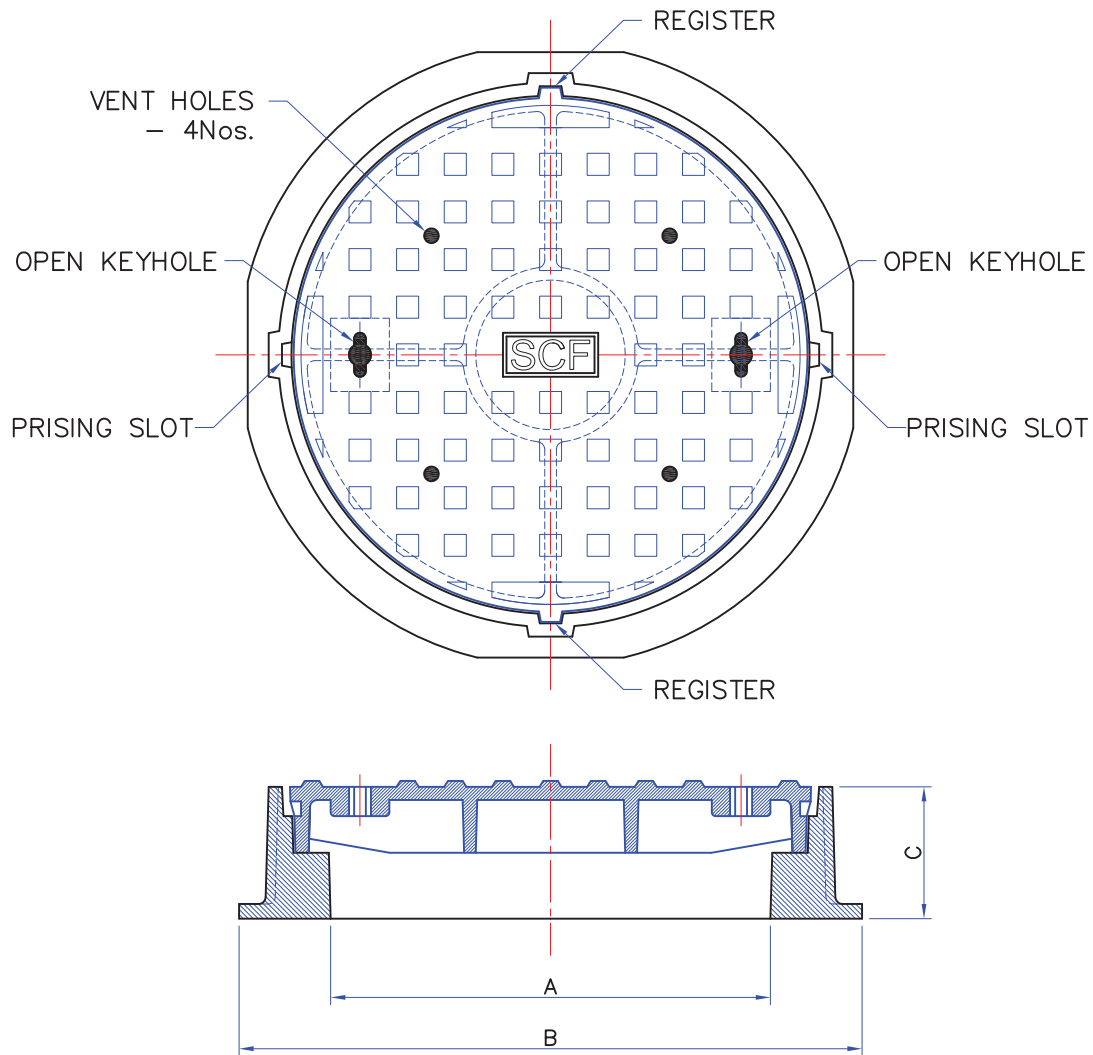

Item code	Clear Opening A(mm)	Over Base B(mm)	Depth C(mm)	Weight (kg)	Loading (Tons)	Standard
MC-5 (HD)	ø600	ø850	180	250	40	EN124

ALL WEIGHTS ARE SUBJECT TO ± 5%

(IF IN DOUBT, PLEASE ASK)

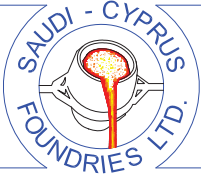

شركة المصنع السعودي القبرصي لسبك و تشكيل المادن المحدودة
SAUDI CYPRUS FOUNDRIES LTD.

ITEM CATEGORY: CAST IRON MANHOLES COVERS AND FRAMES

ITEM DESCRIPTION: CIRCULAR COVER AND FRAME

Heavy duty cast iron
 Manhole cover and frame.

Features:
 Blind keyholes.
 Two galvanized steel
 locking bolts.
 Rubber gasket.
 Non rotating cover.
 Three prising slots.

Options:
 Open keyholes.
 T-type frame.

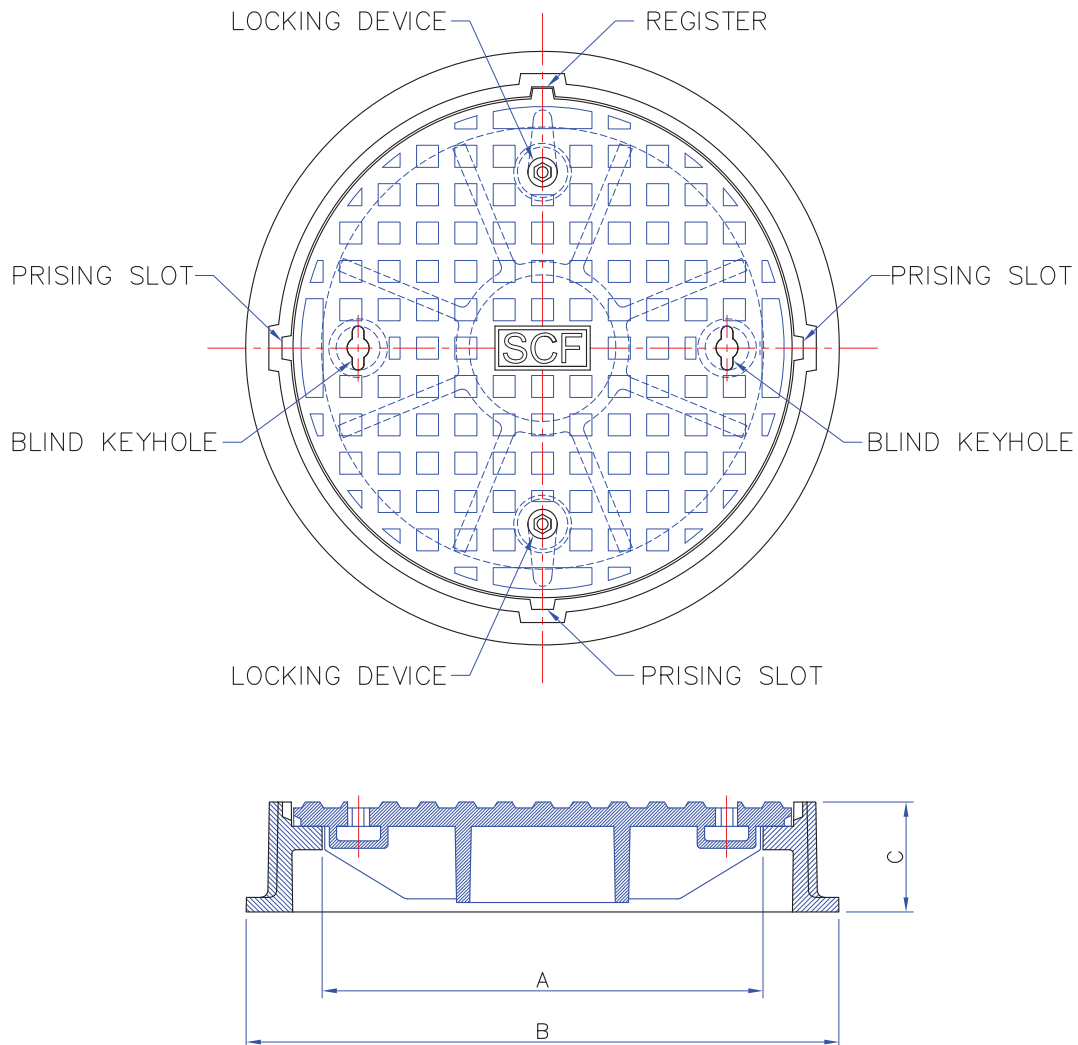

Item code	Clear Opening A(mm)	Over Base B(mm)	Depth C(mm)	Weight (kg)	Loading (Tons)	Standard
MC-6 (HD)	ø600	ø810	150	200	40	EN124

ALL WEIGHTS ARE SUBJECT TO ± 5%

(IF IN DOUBT, PLEASE ASK)

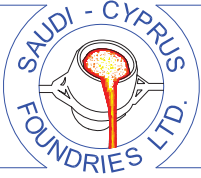

شركة المصنع السعودي القبرصي لسبك و تشكيل المعادن المحدودة
SAUDI CYPRUS FOUNDRIES LTD.

ITEM CATEGORY: CAST IRON MANHOLES COVERS AND FRAMES

ITEM DESCRIPTION: CIRCULAR COVER AND FRAME

Heavy duty cast iron
 Manhole cover and frame.

Features:
 Blind keyholes.
 Two galvanized steel locking bolts.
 Rubber gasket.
 Non rotating cover.
 Three prising slots.

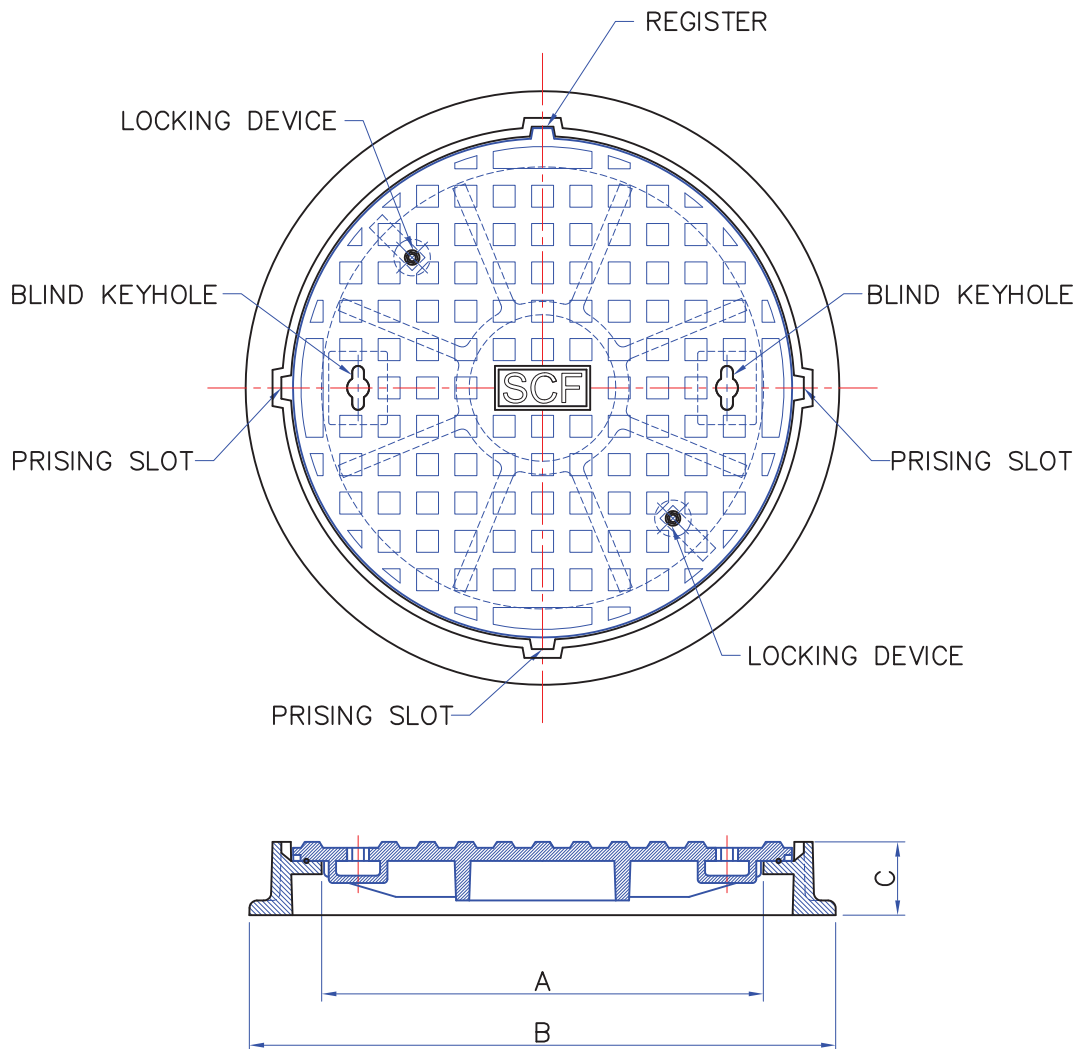

Item code	Clear Opening A(mm)	Over Base B(mm)	Depth C(mm)	Weight (kg)	Loading (Tons)	Standard
MC-7 (HD)	ø610	ø800	100	200	40	EN124

ALL WEIGHTS ARE SUBJECT TO ± 5%

(IF IN DOUBT, PLEASE ASK)

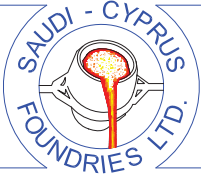

شركة المصنع السعودي القبرصي لسبك و تشكيل المادان المحدودة
SAUDI CYPRUS FOUNDRIES LTD.

ITEM CATEGORY: CAST IRON MANHOLES COVERS AND FRAMES
 ITEM DESCRIPTION: CIRCULAR COVER AND FRAME

Heavy duty cast iron
 Manhole cover and frame.

Features:
 Four prising slots.
 Four holes for anchoring.
 Four air vent holes.

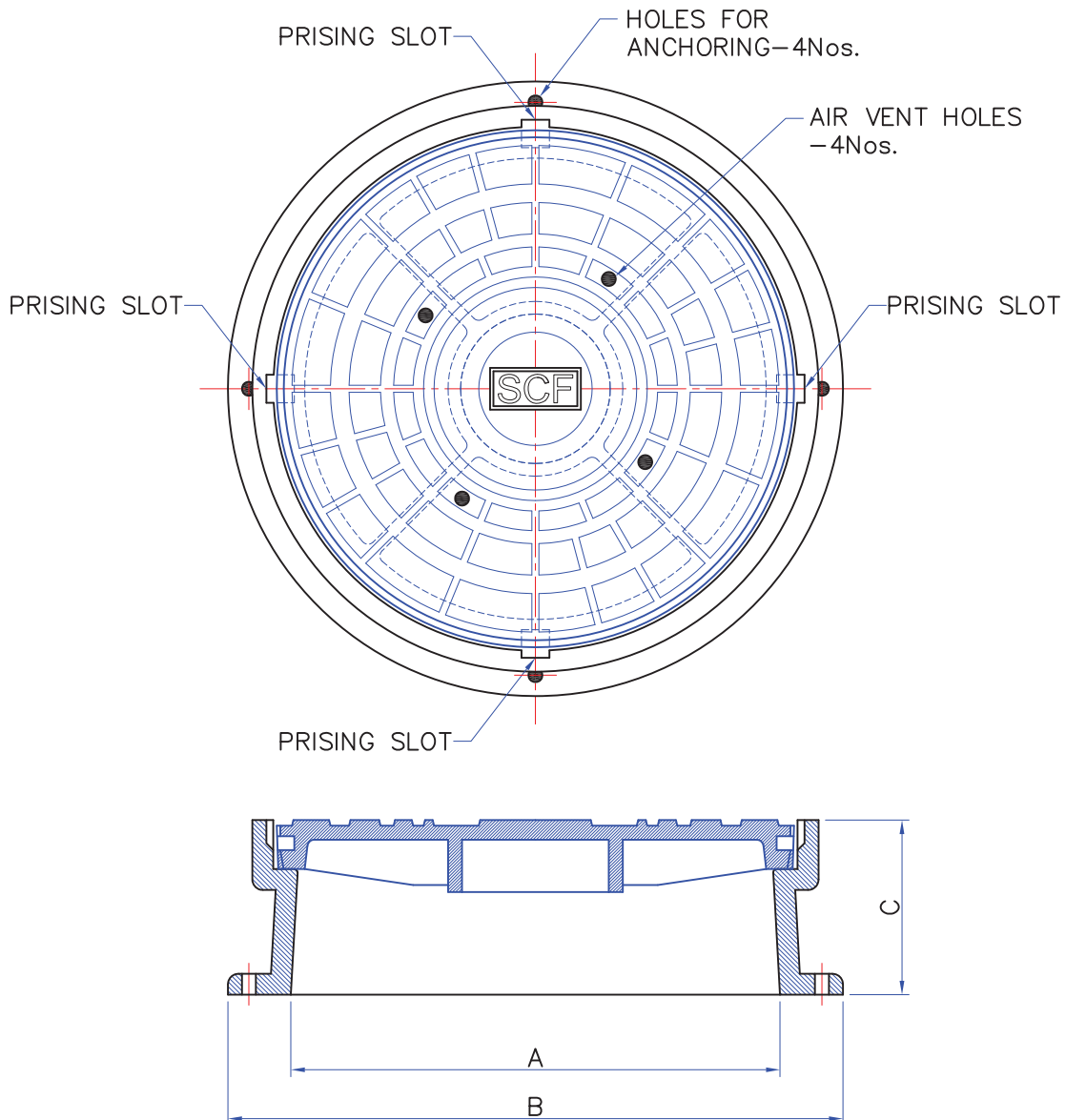

Item code	Clear Opening A(mm)	Over Base B(mm)	Depth C(mm)	Weight (kg)	Loading (Tons)	Standard
MC-8 (HD)	ø680	ø880	250	240	35	EN124

ALL WEIGHTS ARE SUBJECT TO ± 5%

(IF IN DOUBT, PLEASE ASK)

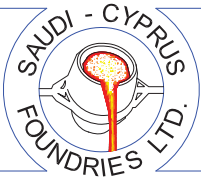

شركة المصنع السعودي القبرصي لسبك و تشكيل المعادن المحدودة
SAUDI CYPRUS FOUNDRIES LTD.



CAST IRON MANHOLE COVERS AND FRAMES



SQUARE FRAMES AND CIRCULAR COVERS



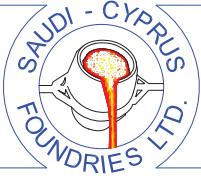

ITEM CATEGORY: CAST IRON MANHOLES COVERS AND FRAMES

ITEM DESCRIPTION: SQUARE FRAME AND CIRCULAR COVER

Medium
 Heavy duty cast iron
 Manhole cover and frame.

Features:
 Blind keyholes.
 Non rotating cover.
 One prising slot.

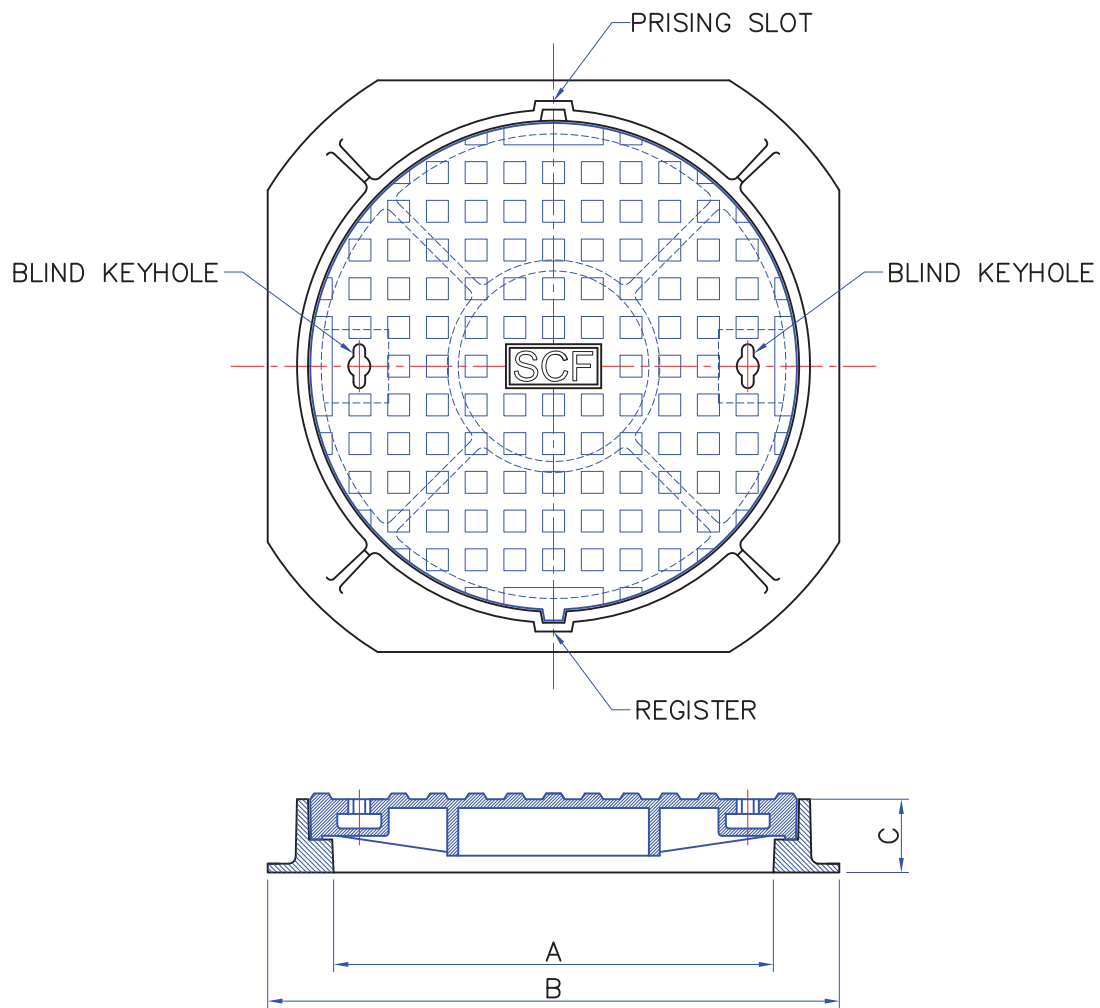

Item code	Clear Opening A(mm)	Over Base B(mm)	Depth C(mm)	Weight (kg)	Loading (Tons)	Standard
SC-1 (MD)	ø500	650 sq.	100	120	15	EN124
SC-1 (HD)	ø500	650sq.	100	150	35	EN124
SC-2 (MD)	ø600	780sq.	100	160	15	EN124
SC-2 HD)	ø600	780sq.	100	185	35	EN124

ALL WEIGHTS ARE SUBJECT TO ± 5%

(IF IN DOUBT, PLEASE ASK)

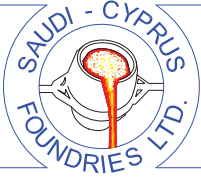

ITEM CATEGORY: CAST IRON MANHOLES COVERS AND FRAMES

ITEM DESCRIPTION: SQUARE FRAME AND CIRCULAR COVER

Heavy duty Cast iron
 Manhole cover and frame.

Features:
 Blind keyholes.
 Three locking bolts.
 One prising slot.
 Rubber gasket.

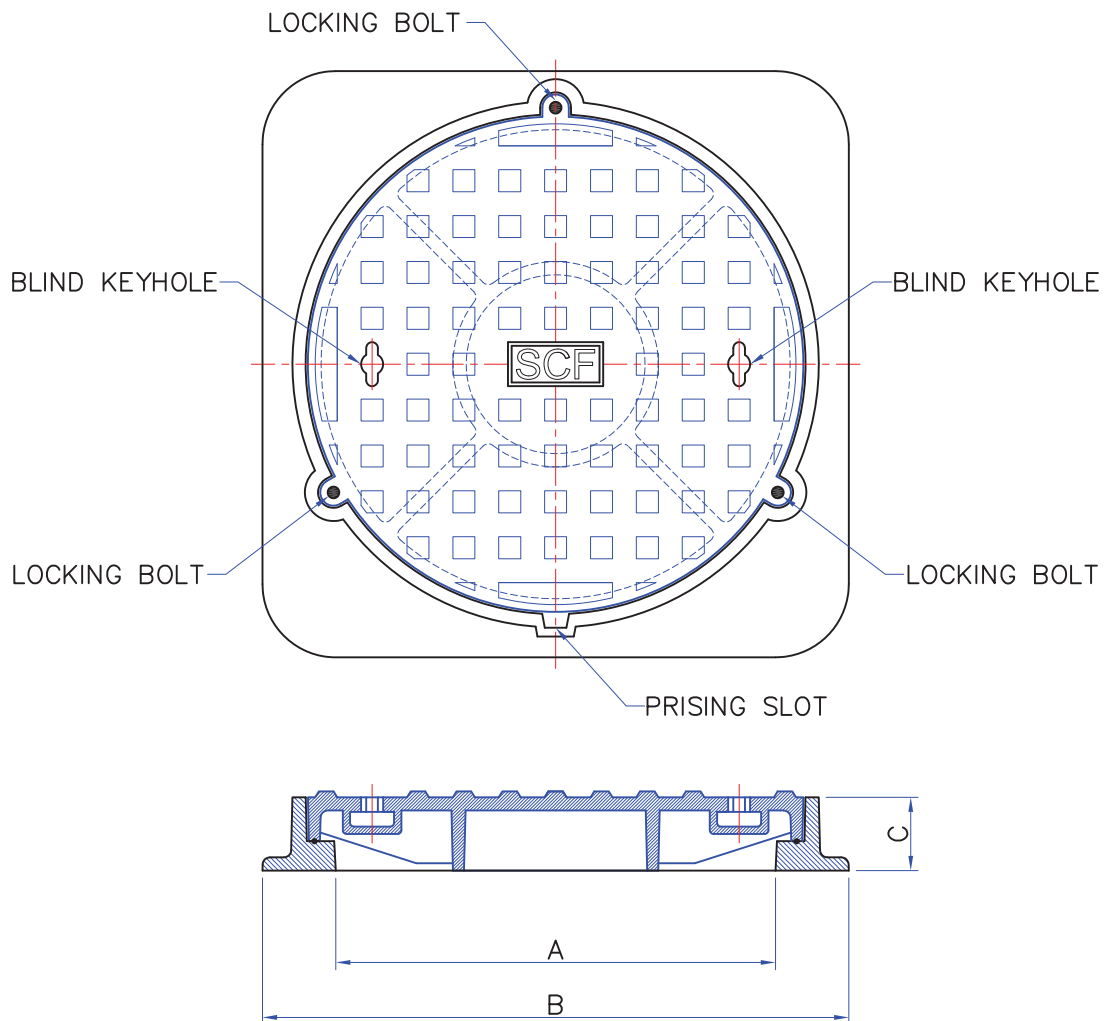

Item code	Clear Opening A(mm)	Over Base B(mm)	Depth C(mm)	Weight (kg)	Loading (Tons)	Standard
SC-3 (HD)	ø600	800sq	100	190	35	EN124

ALL WEIGHTS ARE SUBJECT TO ± 5%

(IF IN DOUBT, PLEASE ASK)

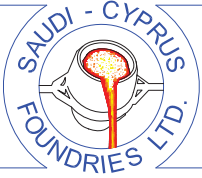

شركة المصنع السعودي القبرصي لسبك و تشكيل المادن المحدودة
SAUDI CYPRUS FOUNDRIES LTD.

ITEM CATEGORY: CAST IRON MANHOLES COVERS AND FRAMES

ITEM DESCRIPTION: SQUARE FRAME AND CIRCULAR COVER

Heavy duty cast iron
 Manhole cover and frame.

Options:
 Open keyholes

Features:
 Two blind keyholes.
 Non rotating cover.
 Two prising slots.
 Two stainless steel locking bolts.
 Four holes for anchoring.

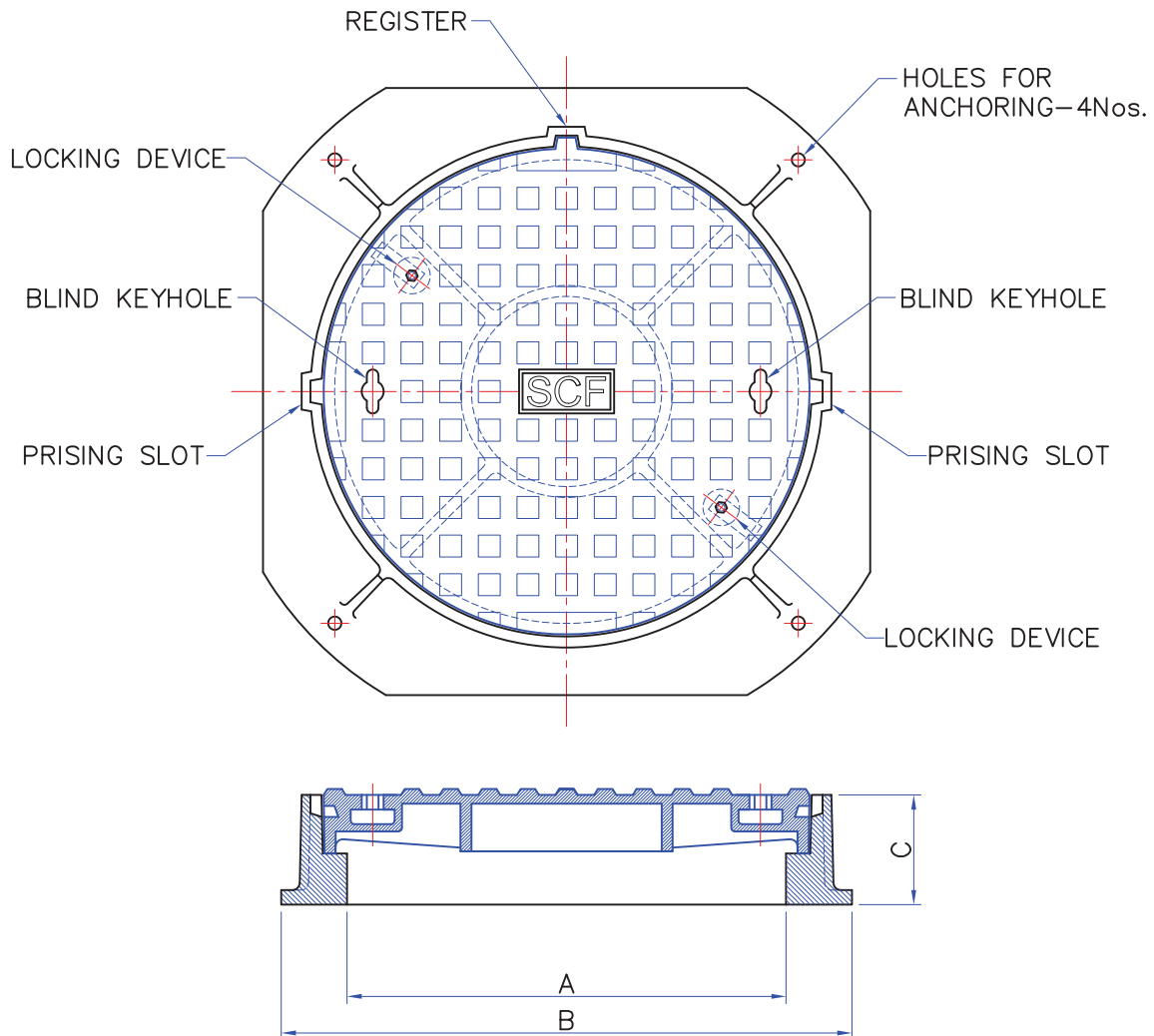

Item code	Clear Opening A(mm)	Over Base B(mm)	Depth C(mm)	Weight (kg)	Loading (Tons)	Standard
SC-4 (HD)	ø600	830 sq.	150	200	40	EN124

ALL WEIGHTS ARE SUBJECT TO ± 5%

(IF IN DOUBT, PLEASE ASK)

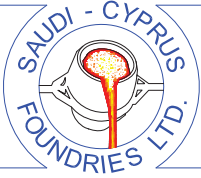

شركة المصنع السعودي القبرصي لسبك و تشكيل المادن المحدودة
SAUDI CYPRUS FOUNDRIES LTD.

ITEM CATEGORY: CAST IRON MANHOLES COVERS AND FRAMES

ITEM DESCRIPTION: SQUARE FRAME AND CIRCULAR COVER

Multi duty, Air tight
 Large cast iron
 Manhole cover and frame.

Features:
 Single seal.
 Two blind keyholes.
 Non rotating cover.
 Two prising slots.

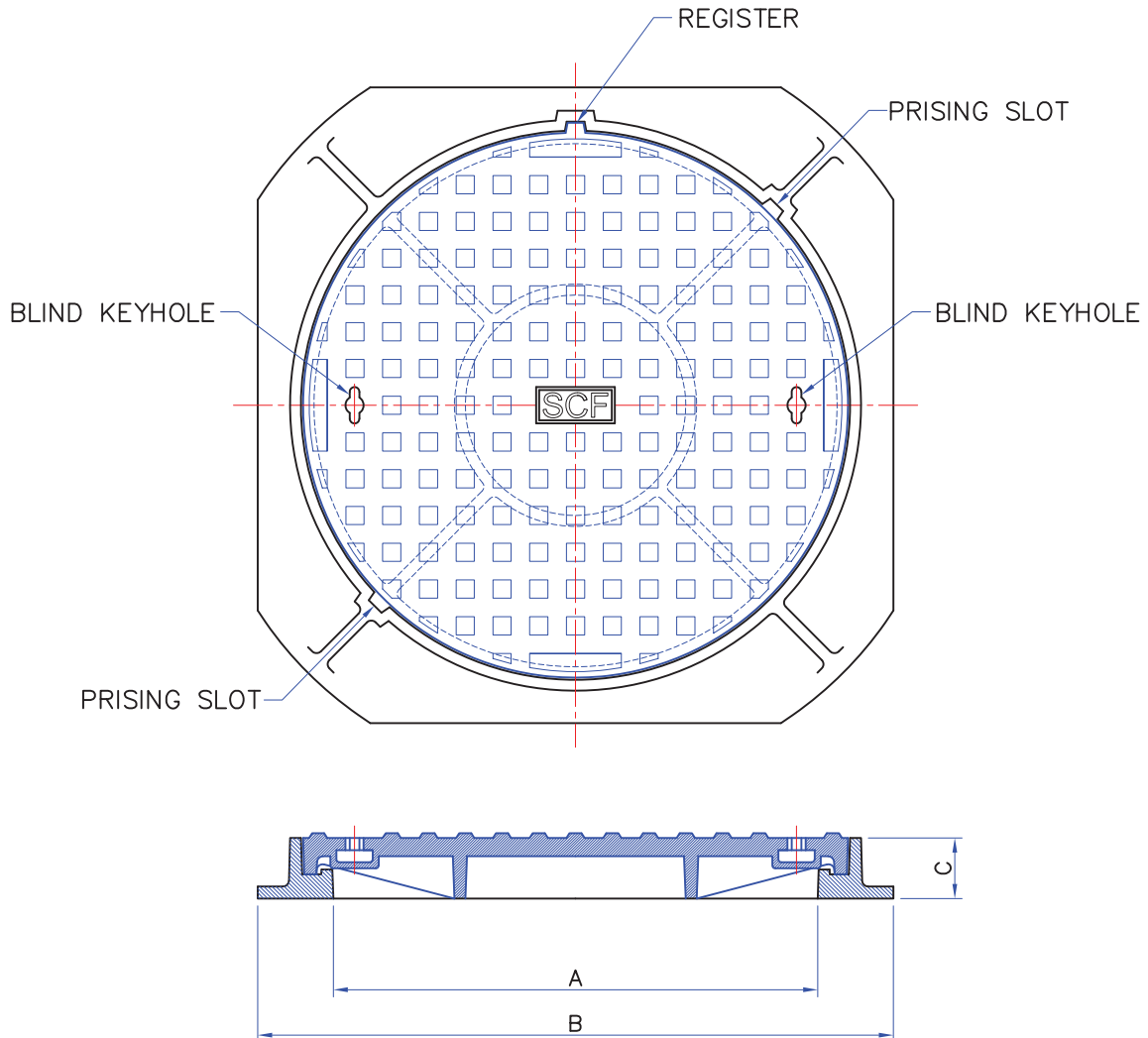

Item code	Clear Opening A(mm)	Over Base B(mm)	Depth C(mm)	Weight (kg)	Loading (Tons)	Standard
SC-5 (HD)	ø800	1050 sq.	100	250	15	EN124
SC-6 (HD)	ø800	1050 sq.	100	310	35	EN124

ALL WEIGHTS ARE SUBJECT TO ± 5%

(IF IN DOUBT, PLEASE ASK)

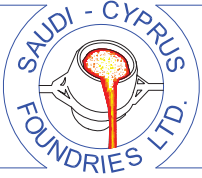

شركة المصنع السعودي القبرصي لسبك و تشكيل المعادن المحدودة
SAUDI CYPRUS FOUNDRIES LTD.

ITEM CATEGORY: CAST IRON MANHOLES COVERS AND FRAMES

ITEM DESCRIPTION: SQUARE FRAME AND CIRCULAR COVER

Light duty cast iron
 Manhole cover and frame.

Features:
 Open keyhole.

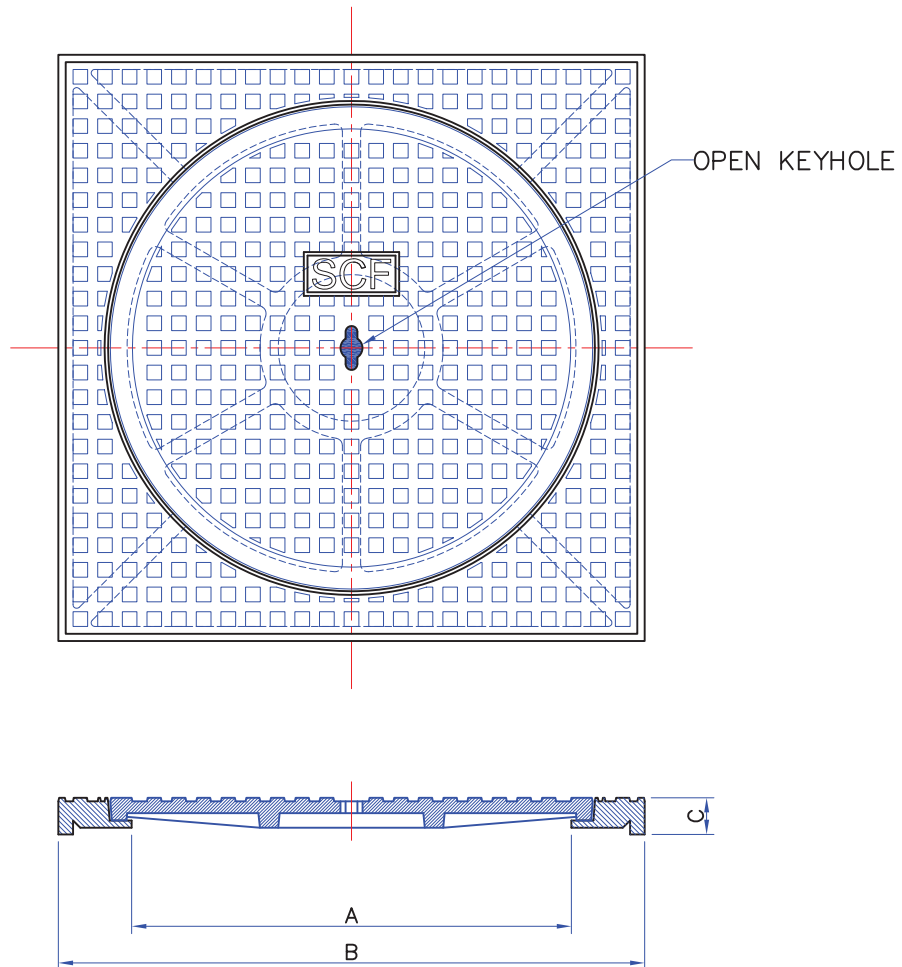

Item code	Clear Opening A(mm)	Over Base B(mm)	Depth C(mm)	Weight (kg)
SC-7 (LD)	ø415	600	60	74
SC-8 (LD)	ø550	700	45	85
SC-9 (LD)	ø600	800	45	95
SC-10 (LD)	ø600	890	50	135
SC-11 (LD)	ø600	900	45	140
SC-12 (LD)	ø600	1000	50	155
SC-13 (LD)	ø600	1000	50	200

ALL WEIGHTS ARE SUBJECT TO ± 5%

(IF IN DOUBT, PLEASE ASK)

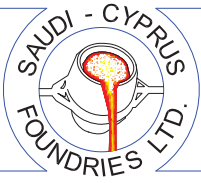

شركة المصنع السعودي القبرصي لسبك و تشكيل المعادن المحدودة
SAUDI CYPRUS FOUNDRIES LTD.



CAST IRON MANHOLE COVERS AND FRAMES



SQUARE FRAMES AND COVERS

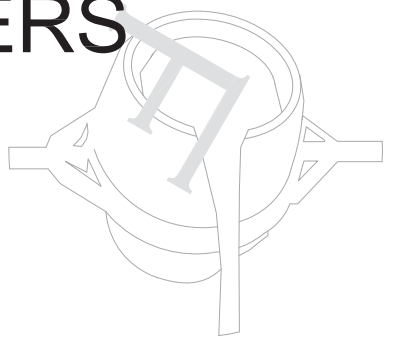

ITEM CATEGORY: CAST IRON MANHOLES COVERS AND FRAMES

ITEM DESCRIPTION: SQUARE COVER AND FRAME

Low-Medium and Heavy
 Multi duty, Air tight,
 Cast iron manhole
 Cover and frame.

Features:
 Two Blind keyholes.
 One way fit.

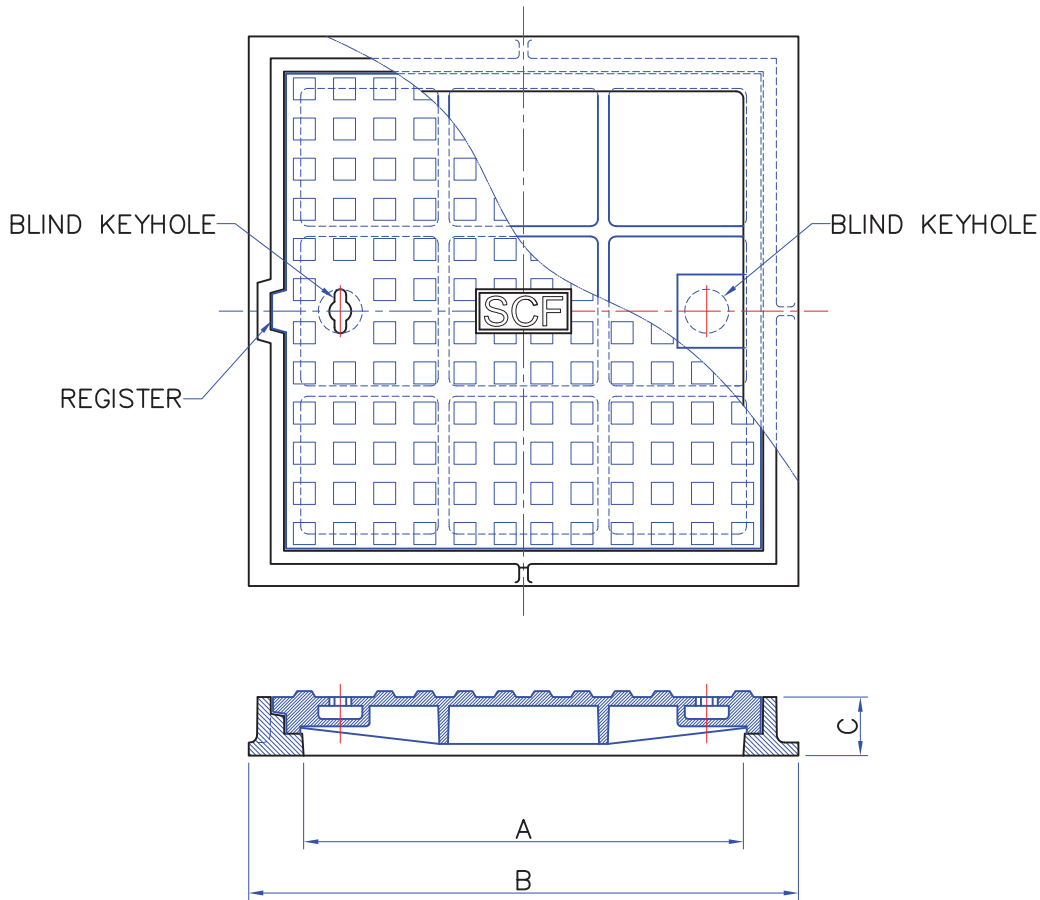

Item code	Clear Opening A(mm)	Over Base B(mm)	Depth C(mm)	Weight (kg)	Loading (Tons)	Standard
SF-1 (MD)	500sq	650sq	80	90	15	EN124
SF-1 (HD)	500sq	650sq	100	140	35	EN124
SF-2 (LD)	600sq	750sq	80	100	5	EN124
SF-2 (MD)	600sq	750sq	80	125	15	EN124
SF-2 (HD)	600sq	750sq	80	170	35	EN124
SF-2 (ALD)	600sq	700sq	50	74	1	EN124
SF-3 (HD)	600sq	750sq	100	200	40	EN124
SF-3 (AHD)	600sq	800sq	100	210	35	EN124
SF-3 (CHD)	600sq	750sq	80	400	90	EN124

ALL WEIGHTS ARE SUBJECT TO $\pm 5\%$

(IF IN DOUBT, PLEASE ASK)

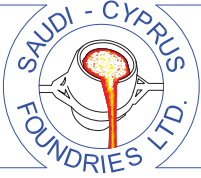

شركة المصنع السعودي القبرصي لسبك و تشكيل المعادن المحدودة
SAUDI CYPRUS FOUNDRIES LTD.

ITEM CATEGORY: CAST IRON MANHOLES COVERS AND FRAMES

ITEM DESCRIPTION: SQUARE COVER AND FRAME

Multi duty, Air tight
 Cast iron Manhole
 Cover and frame.

Features:
 Single seal.
 Four Blind keyholes.
 One way fit.

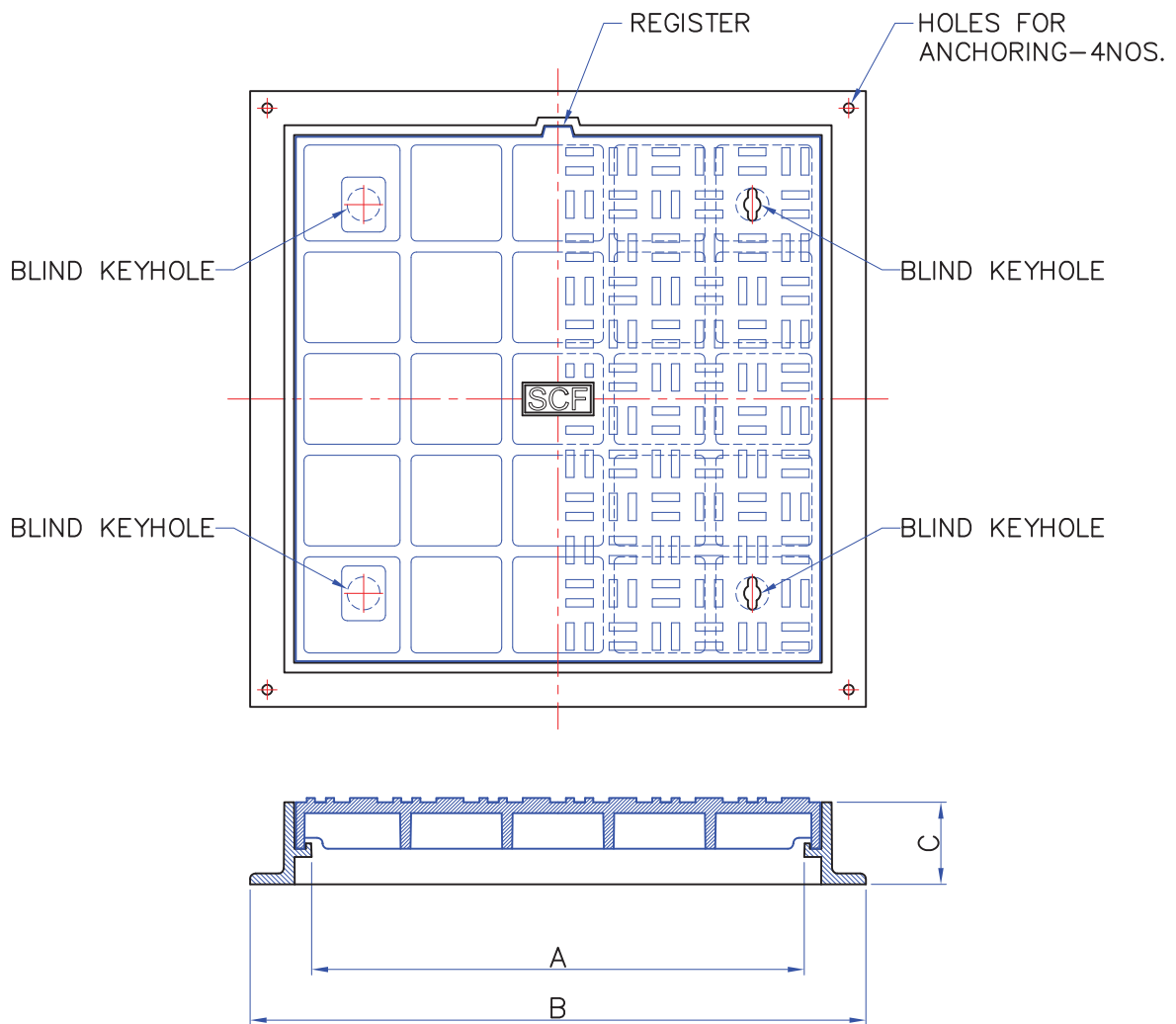

Item code	Clear Opening A(mm)	Over Base B(mm)	Depth C(mm)	Weight (kg)	Loading (Tons)	Standard
SF-4 (MD)	900sq	1125sq	150	390	15	EN124
SF-4 (HD)	900sq	1125sq	150	450	35	EN124
SF-5 (HD)	900sq	1125sq	185	475	35	EN124

ALL WEIGHTS ARE SUBJECT TO $\pm 5\%$

(IF IN DOUBT, PLEASE ASK)

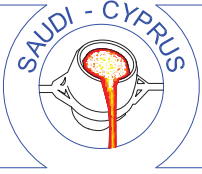

شركة المصنع السعودي القبرصي لسبك و تشكيل المادان المحدودة
SAUDI CYPRUS FOUNDRIES LTD.

ITEM CATEGORY: CAST IRON MANHOLES COVERS AND FRAMES

ITEM DESCRIPTION: SQUARE COVER AND FRAME

Multi duty, Air tight
 Cast iron manhole
 Cover and frame.

Features:
 Single seal.
 Two blind keyholes.
 One way fit.

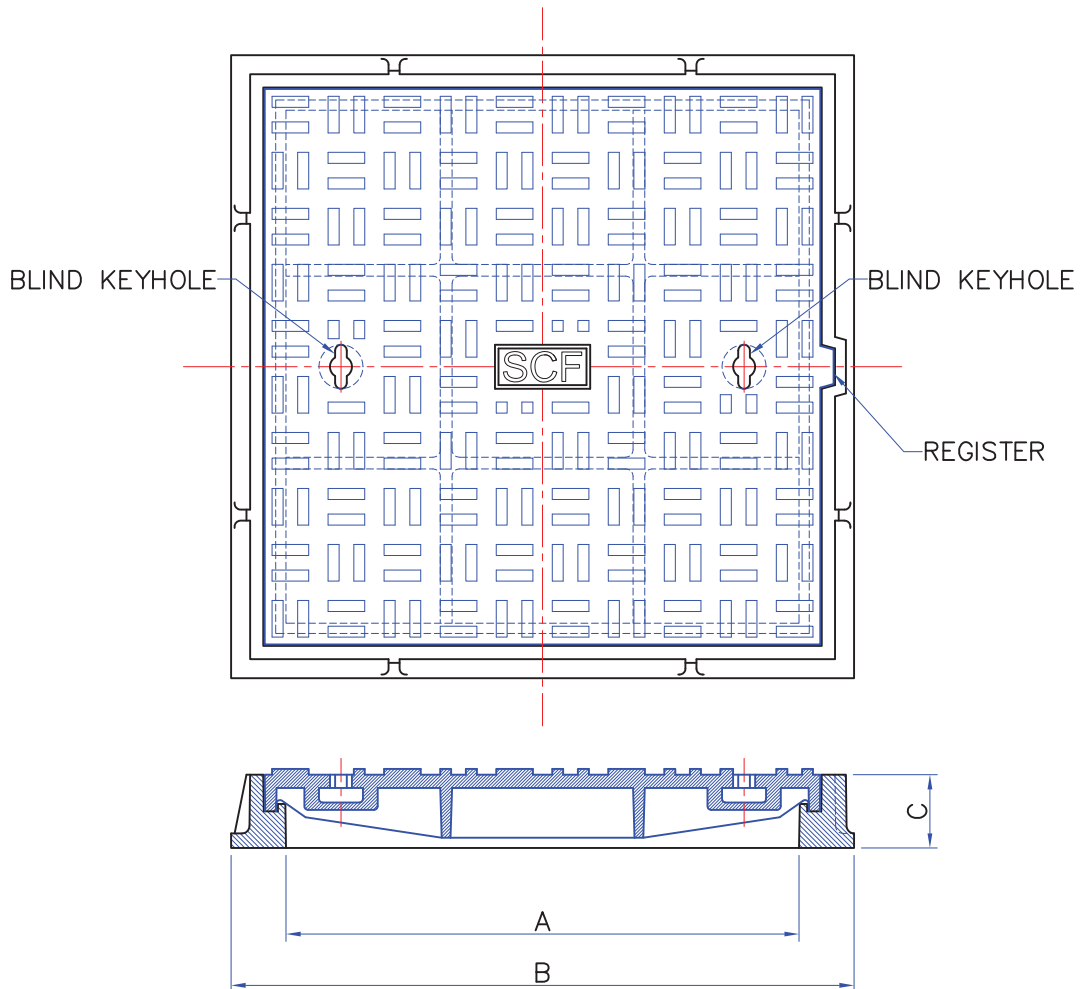

Item code	Clear Opening A(mm)	Over Base B(mm)	Depth C(mm)	Weight (kg)	Loading (Tons)	Standard
SF-6 (LD)	700sq	850sq	100	150	1	EN124
SF-6 (MD)	700sq	850sq	100	200	15	EN124
SF-6 (HD)	700sq	850sq	100	270	35	EN124
SF-7 (MD)	800sq	960sq	100	270	15	EN124
SF-7 (HD)	800sq	960sq	100	320	35	EN124
SF-8 (LD)	900sq	1100sq	100	270	1	EN124
SF-8 (MD)	900sq	1100sq	100	330	15	EN124
SF-8 (HD)	900sq	1100sq	100	440	35	EN124

ALL WEIGHTS ARE SUBJECT TO ± 5%

(IF IN DOUBT, PLEASE ASK)

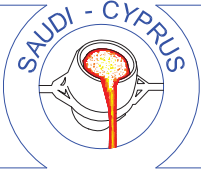

شركة المصنع السعودي القبرصي لسبك و تشكيل المعادن المحدودة
SAUDI CYPRUS FOUNDRIES LTD.

ITEM CATEGORY: CAST IRON MANHOLES COVERS AND FRAMES

ITEM DESCRIPTION: SQUARE COVER AND FRAME

Multi duty,
 Large Cast iron
 Manhole cover and
 frame.

Features:
 Blind keyholes.
 One way fit.

Options:
 Double cover.

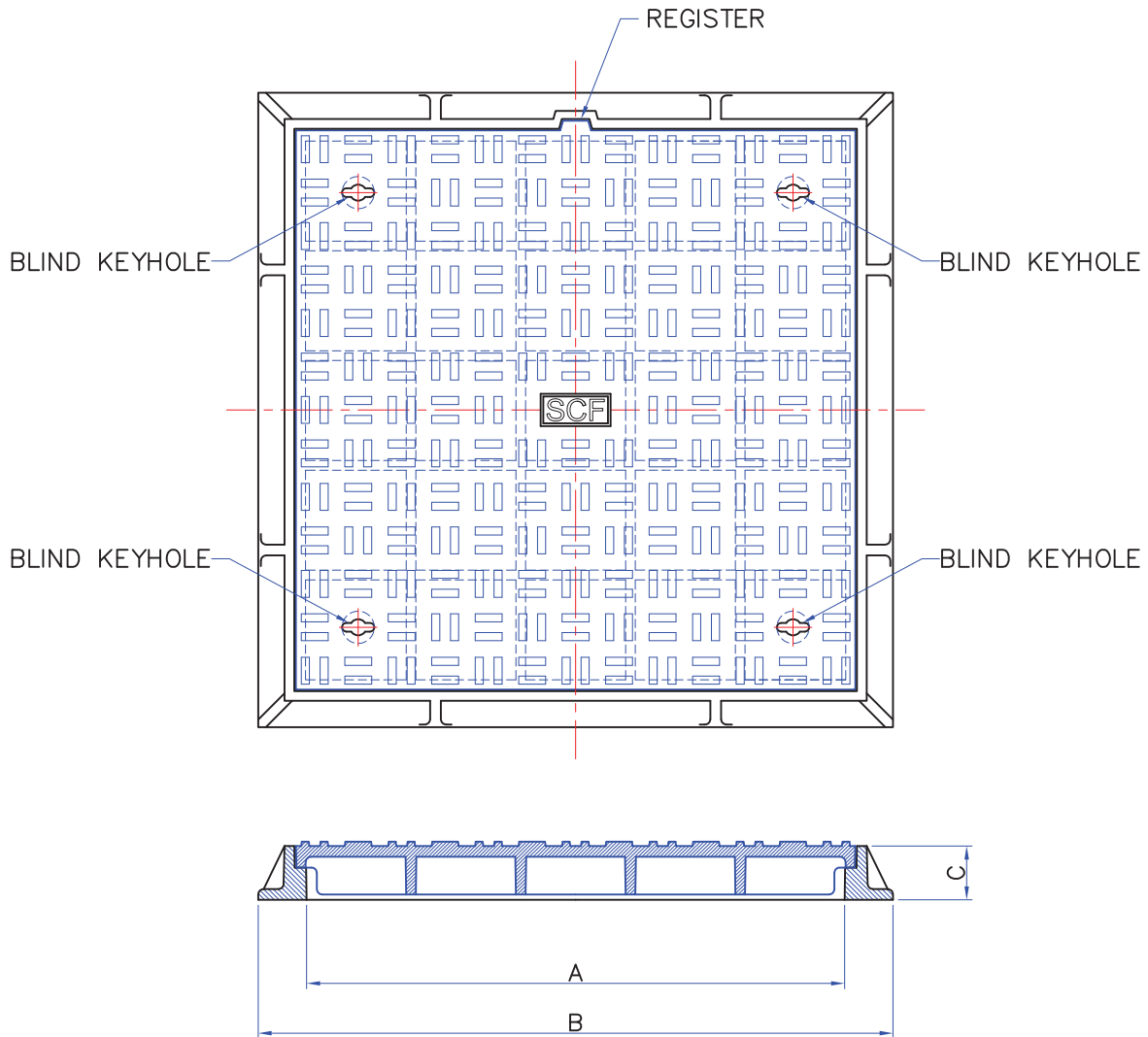

Item code	Clear Opening A(mm)	Over Base B(mm)	Depth C(mm)	Weight (kg)	Loading (Tons)	Standard
SF-9 (LD)	1000sq	1180sq	100	350	1	EN124
SF-9 (MD)	1000sq	1180sq	100	400	15	EN124
SF-9 (HD)	1000sq	1180sq	100	450	35	EN124

ALL WEIGHTS ARE SUBJECT TO ± 5%

(IF IN DOUBT, PLEASE ASK)

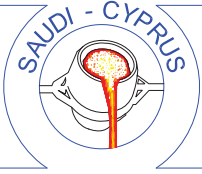

ITEM CATEGORY: CAST IRON MANHOLES COVERS AND FRAMES

ITEM DESCRIPTION: SQUARE COVER AND FRAME

Heavy duty
 Cast iron manhole
 Cover and frame.

Features:
 Blind keyholes.
 One way fit.

Options:
 Open keyholes.

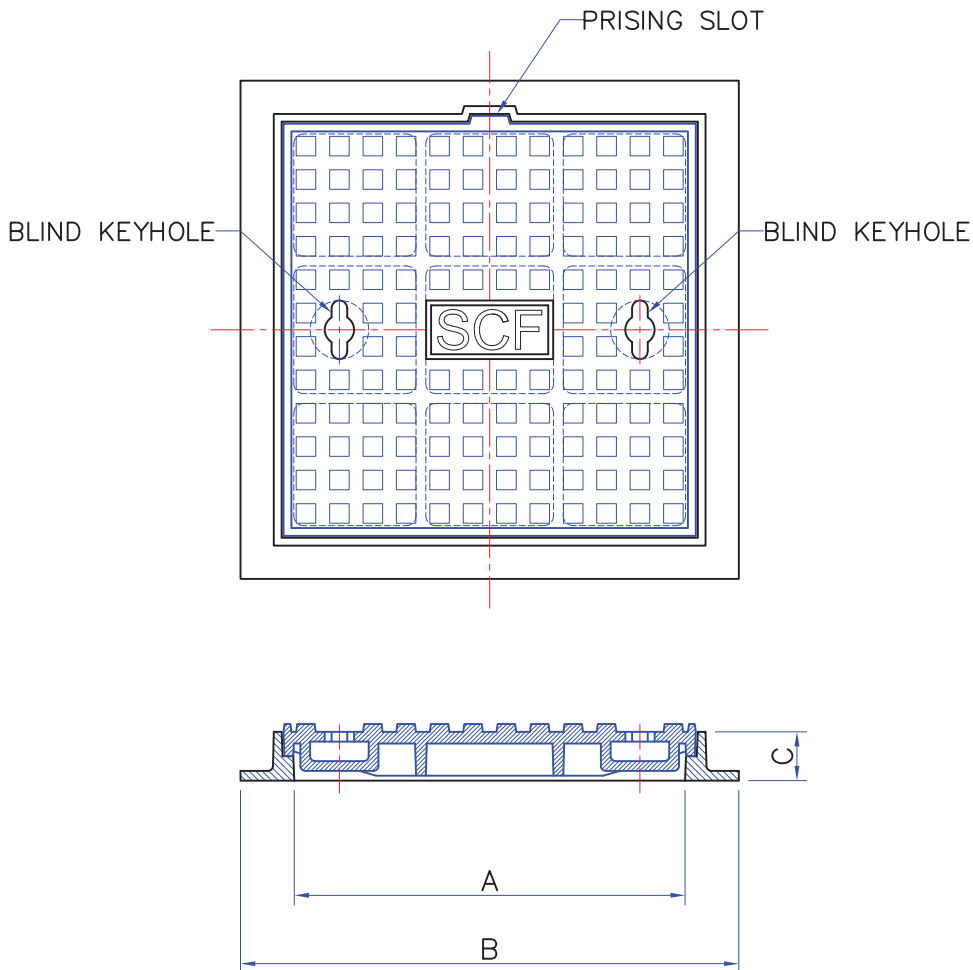

Item code	Clear Opening A(mm)	Over Base B(mm)	Depth C(mm)	Weight (kg)	Loading (Tons)	Standard
SF-10 (LD)	200sq	260sq	50	15	5	EN124
SF-10 (MD)	200sq	260sq	50	20	15	EN124
SF-10 (HD)	200sq	260sq	50	30	35	EN124
SF-11 (LD)	300sq	360sq	50	16	5	EN124
SF-11 (MD)	300sq	360sq	50	25	15	EN124
SF-11 (HD)	300sq	360sq	50	30	35	EN124
SF-12 (LD)	400sq	460sq	50	40	5	EN124
SF-12 (MD)	400sq	510sq	50	60	15	EN124

ALL WEIGHTS ARE SUBJECT TO $\pm 5\%$

(IF IN DOUBT, PLEASE ASK)

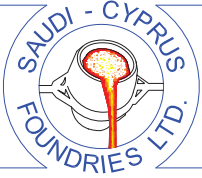

شركة المصنع السعودي القبرصي لسبك و تشكيل المعادن المحدودة
SAUDI CYPRUS FOUNDRIES LTD.

ITEM CATEGORY: CAST IRON RECESSED MANHOLES COVERS AND FRAMES
 ITEM DESCRIPTION: SQUARE COVER AND FRAME

Heavy
 Medium duty, Recessed Cast Iron
 Manhole cover and frame.

Features:
 Concrete infill.
 Blind keyholes.
 SF-13 RC (HD) is
 single seal.

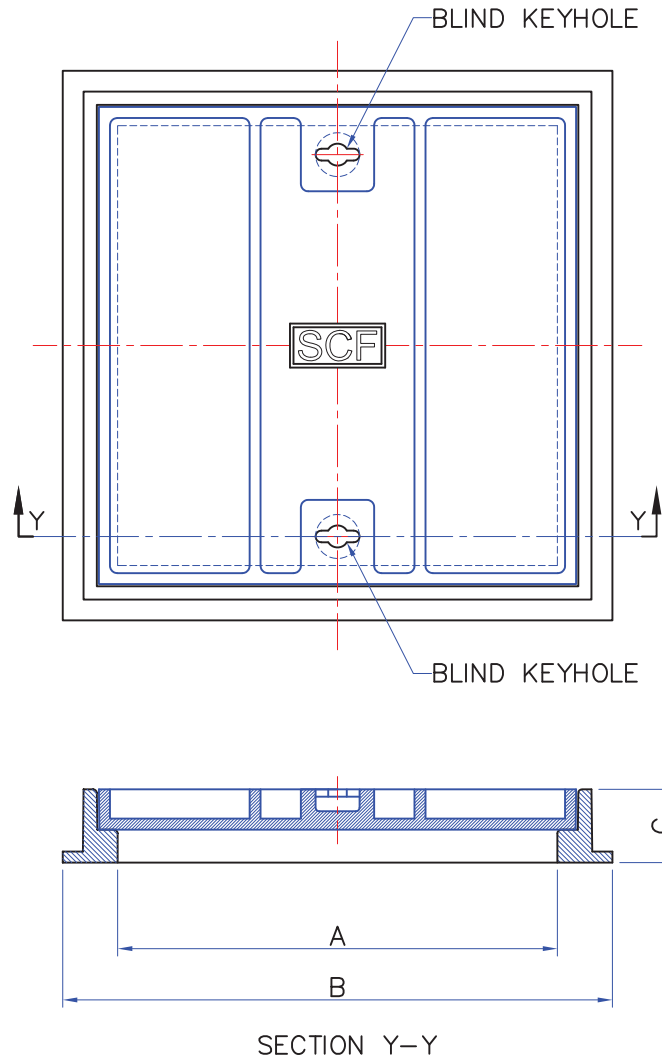

Item code	Clear Opening A(mm)	Over Base B(mm)	Depth C(mm)	Weight (kg)	Loading (Tons)	Standard
SF-13 RC(MD)	600sq	750sq	100	125	15	EN124
SF-13 RC(HD)	600sq	750sq	100	170	35	EN124

ALL WEIGHTS ARE SUBJECT TO ± 5%

(IF IN DOUBT, PLEASE ASK)

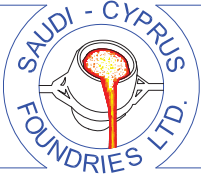

ITEM CATEGORY: CAST IRON RECESSED MANHOLES COVERS AND FRAMES
 ITEM DESCRIPTION: SQUARE COVER AND FRAME

Multi and Heavy duty Cast Iron
 Manhole cover and frame.

Features:
 Blind keyholes.
 One way fit.

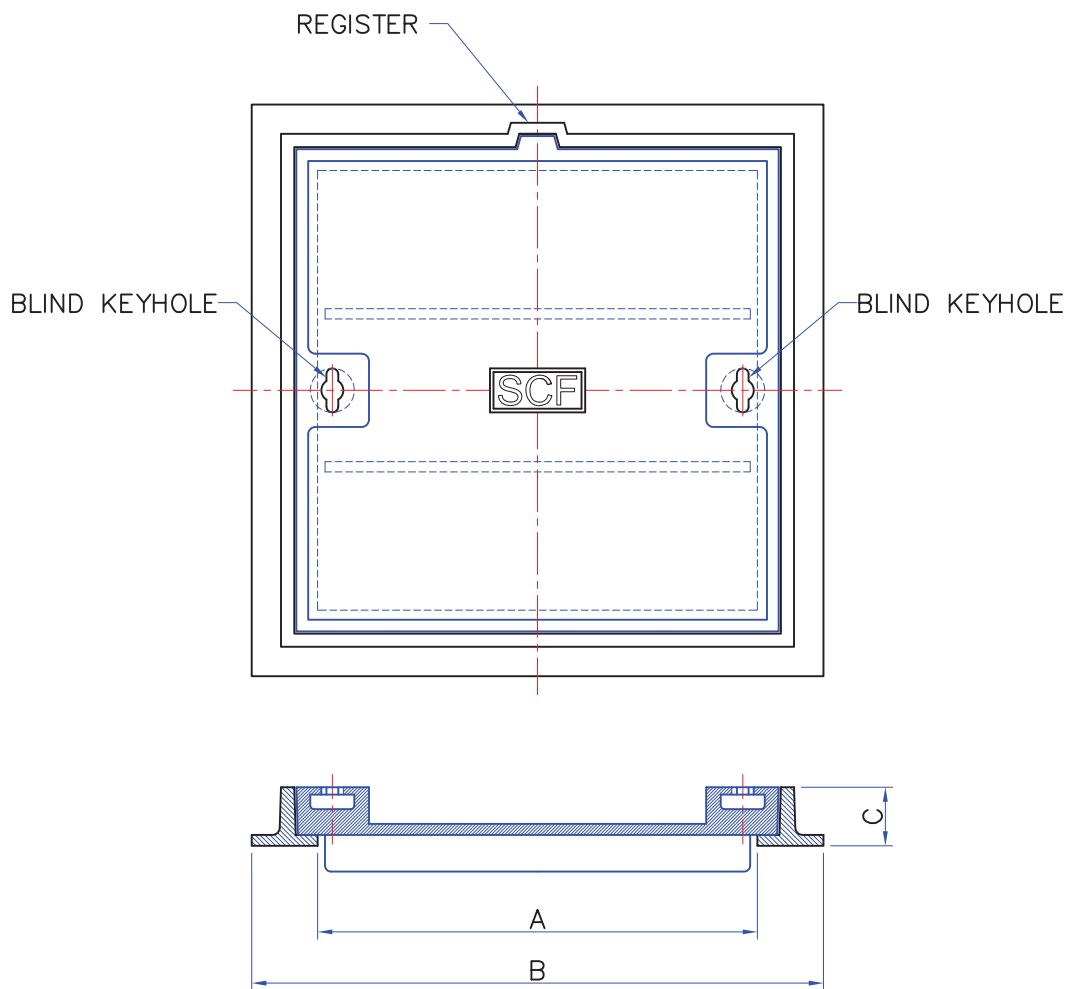

Item code	Clear Opening A(mm)	Over Base B(mm)	Depth C(mm)	Weight (kg)	Loading (Tons)	Standard
SF-14 RC(LD)	600sq	780sq	80	100	1	EN124
SF-14 RC(MD)	600sq	780sq	80	120	15	EN124
SF-14 RC(HD)	600sq	780sq	80	140	35	EN124

ALL WEIGHTS ARE SUBJECT TO $\pm 5\%$

(IF IN DOUBT, PLEASE ASK)

ITEM CATEGORY: CAST IRON RECESSED MANHOLES COVERS AND FRAMES

ITEM DESCRIPTION: SQUARE COVER AND FRAME

Multi duty, recessed Cast iron Manhole cover and frame.

Options:

- Extra rubber sealing.
- Locking bolts.
- Inscription plate.
- Infilling Depth-65 mm.

Features:

- Concrete/Tile infill.
- Double seal.
- Two combined keyholes and prising slots.

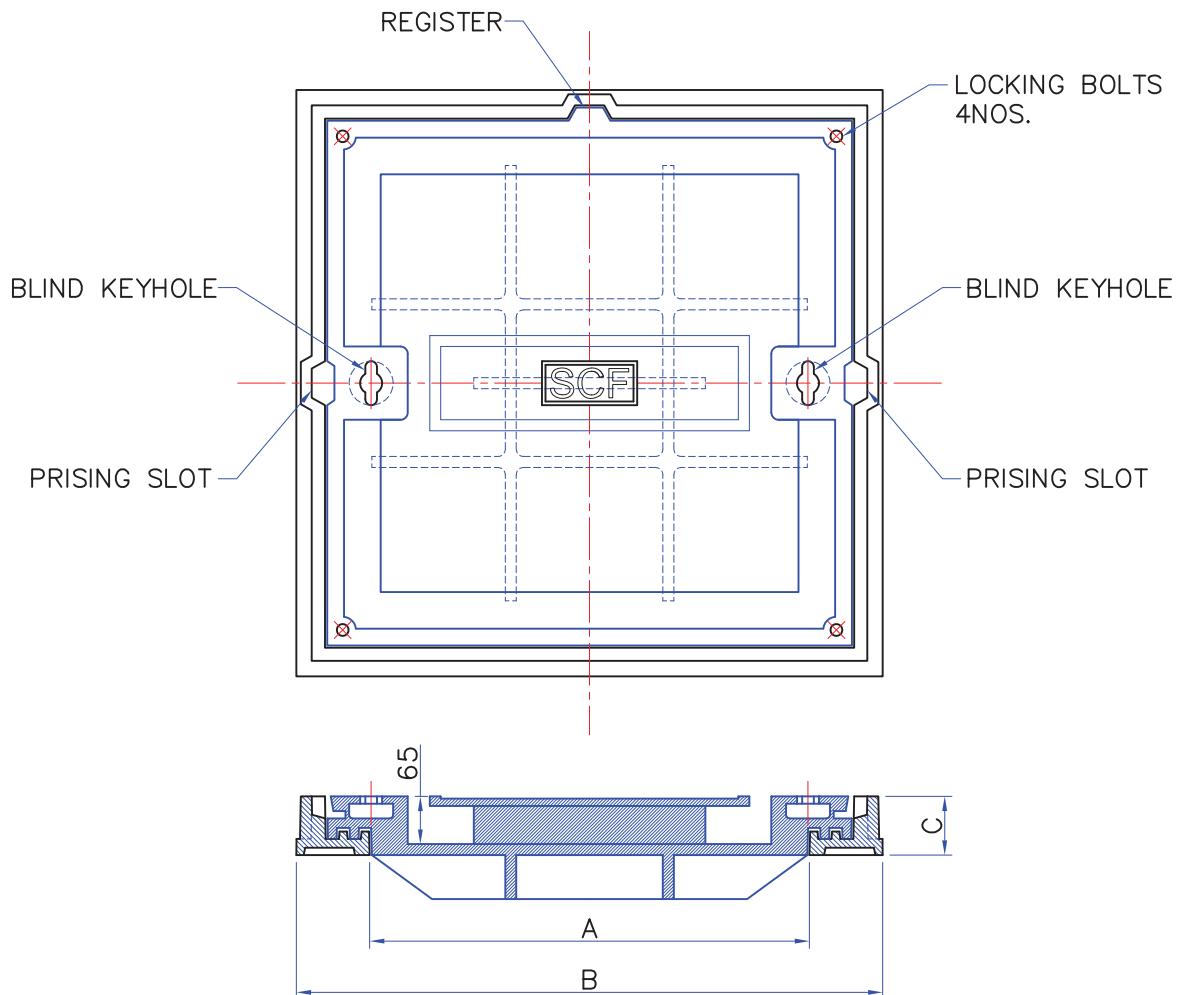

Item code	Clear Opening A(mm)	Over Base B(mm)	Depth C(mm)	Weight (kg)	Loading (Tons)	Standard
SF-15 RC(LD)	600sq	800sq	80	150	1	EN124
SF-15 RC(MD)	600sq	800sq	80	170	15	EN124
SF-15 RC(HD)	600sq	800sq	80	200	35	EN124

ALL WEIGHTS ARE SUBJECT TO $\pm 5\%$

(IF IN DOUBT, PLEASE ASK)

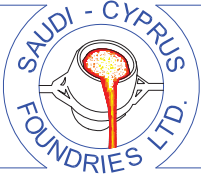

شركة المصنع السعودي القبرصي لسبك و تشكيل المعادن المحدودة
SAUDI CYPRUS FOUNDRIES LTD.

ITEM CATEGORY: CAST IRON RECESSED MANHOLES COVERS AND FRAMES

ITEM DESCRIPTION: SQUARE COVER AND FRAME

Heavy and Medium duty,
 recessed Cast iron
 Manhole cover and frame.

Features:
 Concrete/Tile infill.
 Two blind keyholes.

Infilling Depth:
 Medium duty-40mm.
 Heavy duty-55mm.

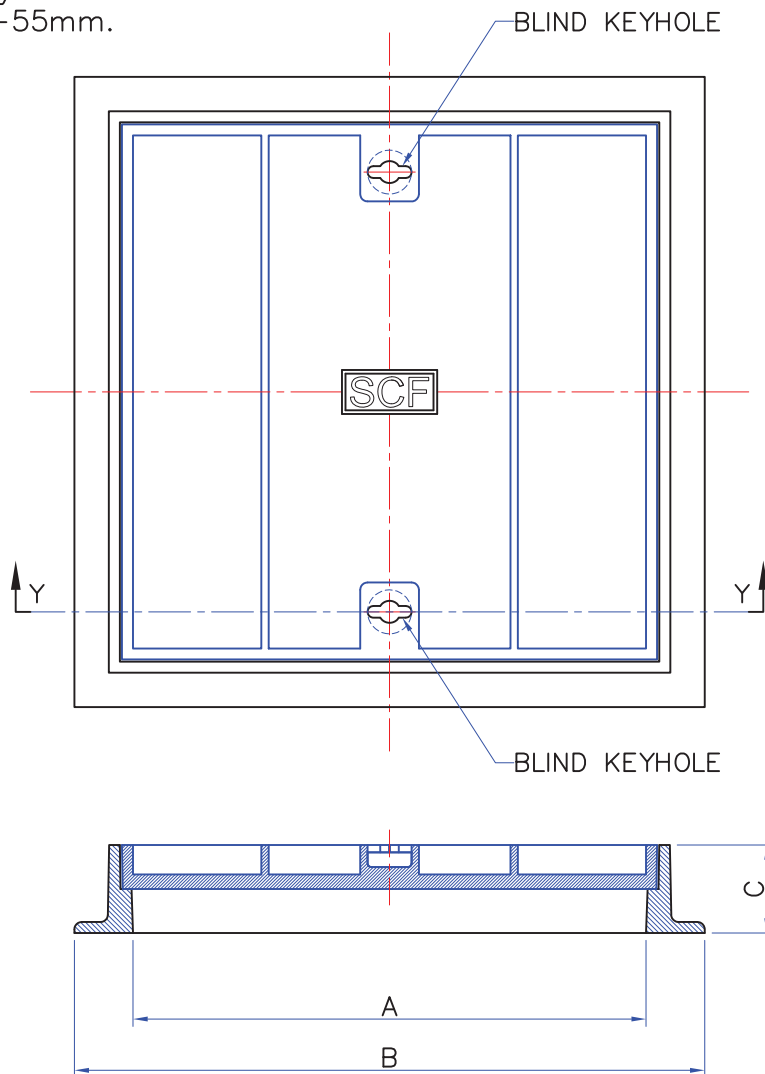

SECTION Y-Y

Item code	Clear Opening A(mm)	Over Base B(mm)	Depth C(mm)	Weight (kg)	Loading (Tons)	Standard
SF-16 RC(MD)	700sq	860sq	120	230	15	EN124
SF-16 RC(HD)	700sq	860sq	120	300	35	EN124
SF-17 RC(MD)	800sq	960sq	120	360	15	EN124
SF-17 RC(HD)	800sq	960sq	120	470	35	EN124

ALL WEIGHTS ARE SUBJECT TO $\pm 5\%$

(IF IN DOUBT, PLEASE ASK)

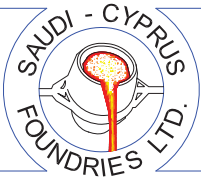

شركة المصنع السعودي القبرصي لسبك و تشكيل المعادن المحدودة
SAUDI CYPRUS FOUNDRIES LTD.



CAST IRON MANHOLE COVERS AND FRAMES



RECTANGULAR FRAMES AND COVERS



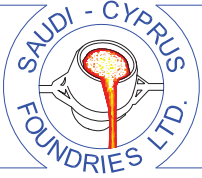

شركة المصنع السعودي القبرصي لسبك و تشكيل المادن المحدودة
SAUDI CYPRUS FOUNDRIES LTD.

ITEM CATEGORY: CAST IRON MANHOLES COVERS AND FRAMES

ITEM DESCRIPTION: RECTANGULAR COVER AND FRAME

Multi duty Cast iron
 Manhole cover and frame.

Features:
 Two blind keyholes.
 One way fit.
 Four holes for anchoring.

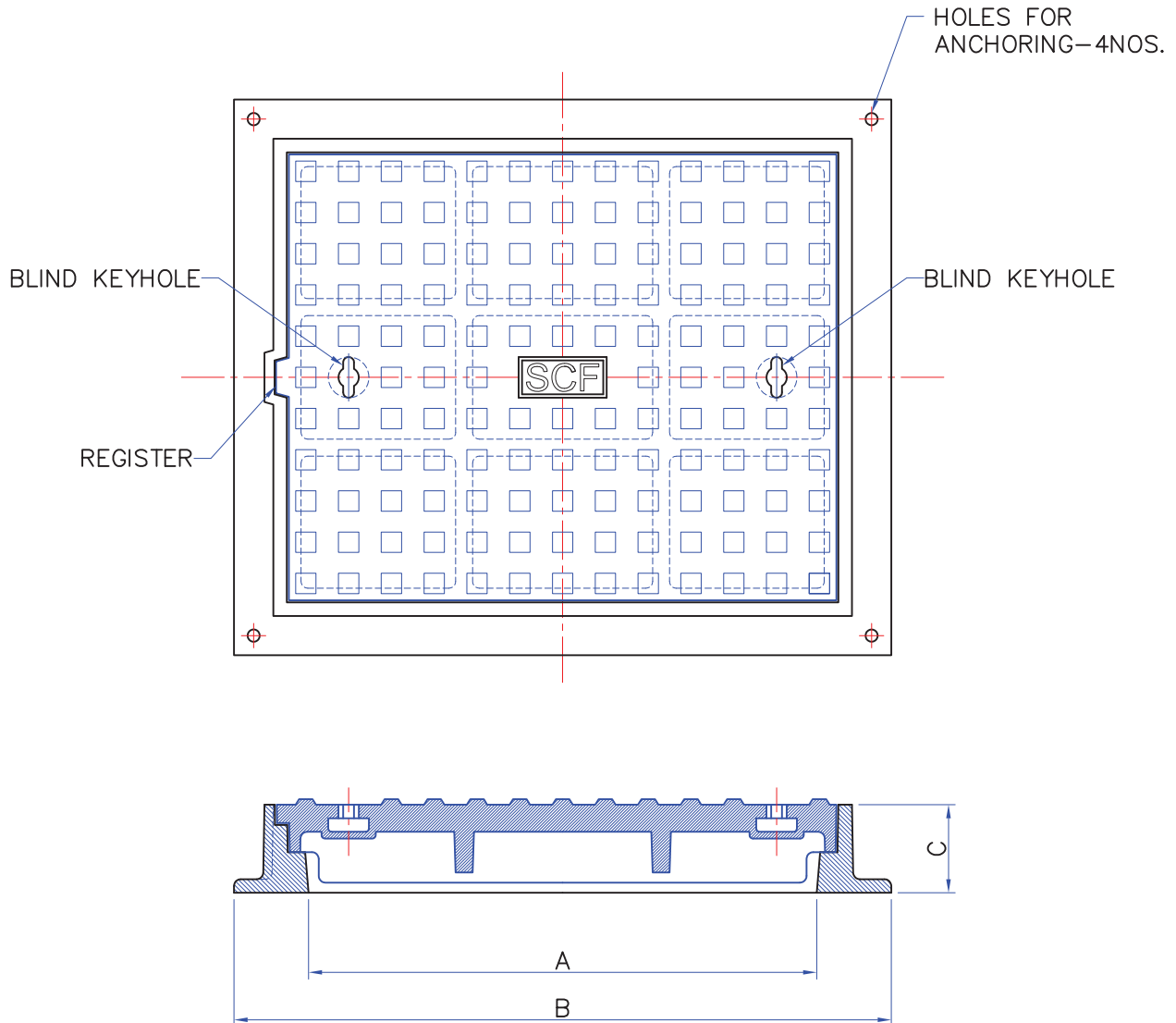

Item code	Clear Opening A(mm)	Over Base B(mm)	Depth C(mm)	Weight (kg)	Loading (Tons)	Standard
RF-1 (MD)	600x450	770x620	100	100	15	EN124
RF-1 (HD)	600x450	770x620	100	140	35	EN124
RF-2 (MD)	750x600	970x820	130	240	15	EN124
RF-2 (HD)	750x600	970x820	130	260	35	EN124

ALL WEIGHTS ARE SUBJECT TO $\pm 5\%$

(IF IN DOUBT, PLEASE ASK)

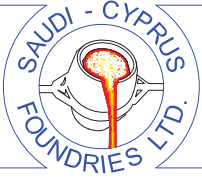

شركة المصنع السعودي القبرصي لسبك و تشكيل المعادن المحدودة
SAUDI CYPRUS FOUNDRIES LTD.

ITEM CATEGORY: CAST IRON MANHOLES COVERS AND FRAMES

ITEM DESCRIPTION: RECTANGULAR COVER AND FRAME

Multi duty, Air tight
 Cast iron manhole
 Cover and frame.

Features:
 Single seal.
 Blind keyholes.
 One way fit.
 Four holes for anchoring.

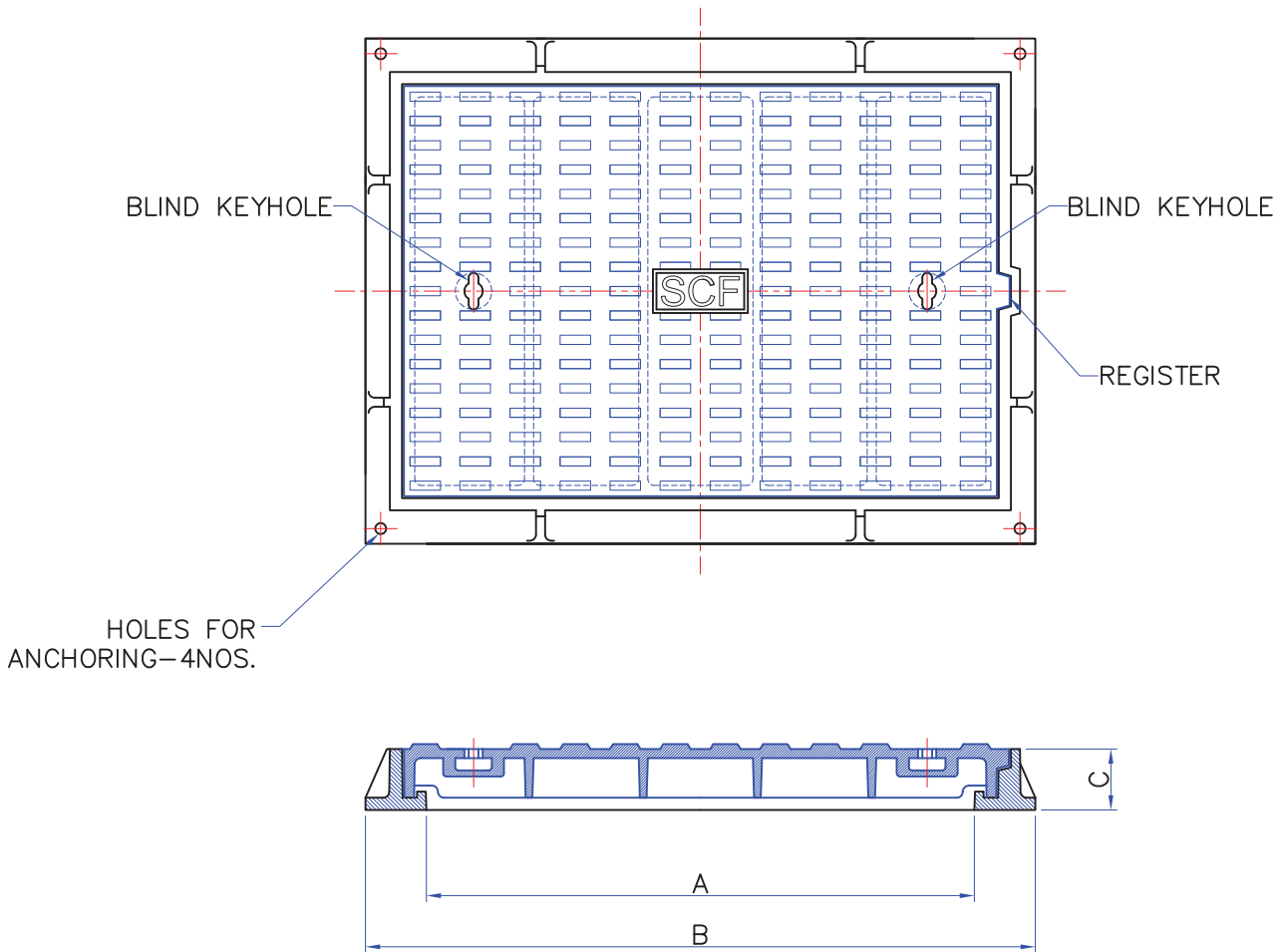

Item code	Clear Opening A(mm)	Over Base B(mm)	Depth C(mm)	Weight (kg)	Loading (Tons)	Standard
RF-3 (MD)	900x600	1100x830	100	225	15	EN124
RF-3 (HD)	900x600	1100x830	150	370	35	EN124

ALL WEIGHTS ARE SUBJECT TO $\pm 5\%$

(IF IN DOUBT, PLEASE ASK)

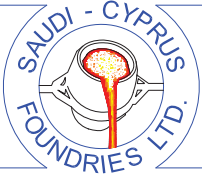

شركة المصنع السعودي القبرصي لسبك و تشكيل المادن المحدودة
SAUDI CYPRUS FOUNDRIES LTD.

ITEM CATEGORY: CAST IRON MANHOLES COVERS AND FRAMES

ITEM DESCRIPTION: RECTANGULAR COVER AND FRAME

Heavy duty, Large
 Cast iron Manhole
 Cover and frame.

Features:
 One way fit.
 Two Blind keyholes.
 Four holes for anchoring.

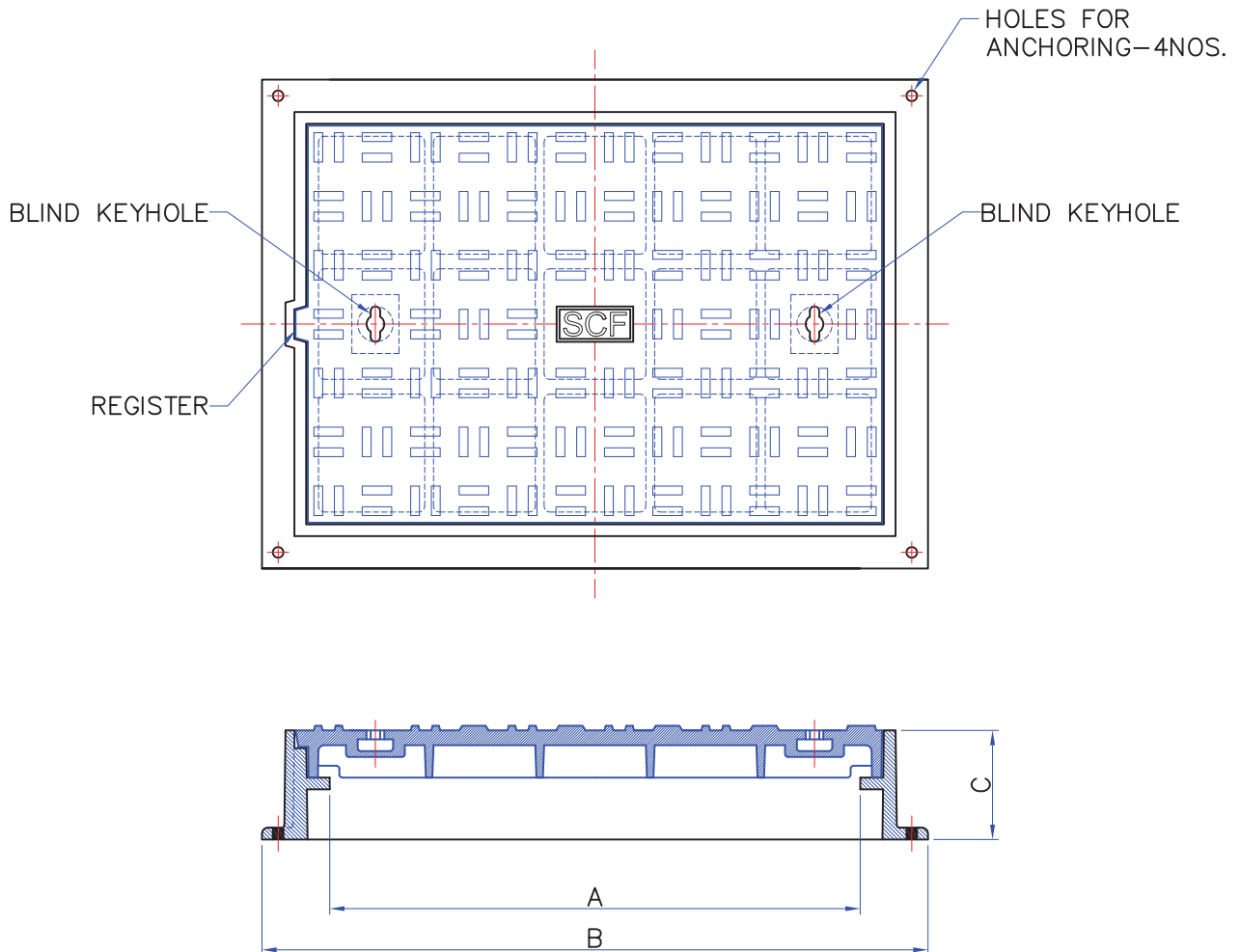

Item code	Clear Opening A(mm)	Over Base B(mm)	Depth C(mm)	Weight (kg)	Loading (Tons)	Standard
RF-4 (HD)	900x600	1130x830	185	335	35	EN124

ALL WEIGHTS ARE SUBJECT TO $\pm 5\%$

(IF IN DOUBT, PLEASE ASK)

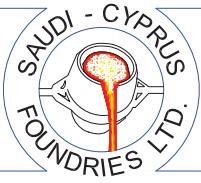

شركة المصنع السعودي القبرصي لسبك و تشكيل المعادن المحدودة
SAUDI CYPRUS FOUNDRIES LTD.

GRATINGS AND FRAMES

CIRCULAR GRATINGS AND FRAMES

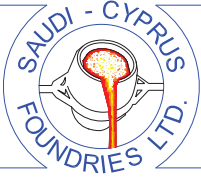

شركة المصنع السعودي القبرصي لسبك و تشكيل المادن المحدودة
SAUDI CYPRUS FOUNDRIES LTD.

ITEM CATEGORY: GRATINGS AND FRAMES
 ITEM DESCRIPTION: CIRCULAR GRATING AND FRAME

Light duty cast iron
 grating and frame.

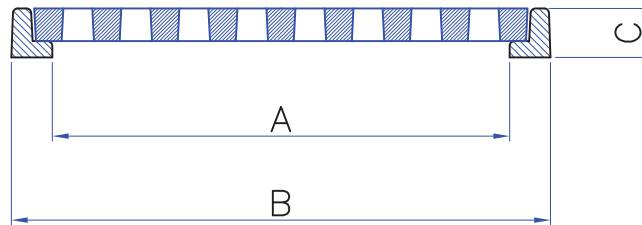
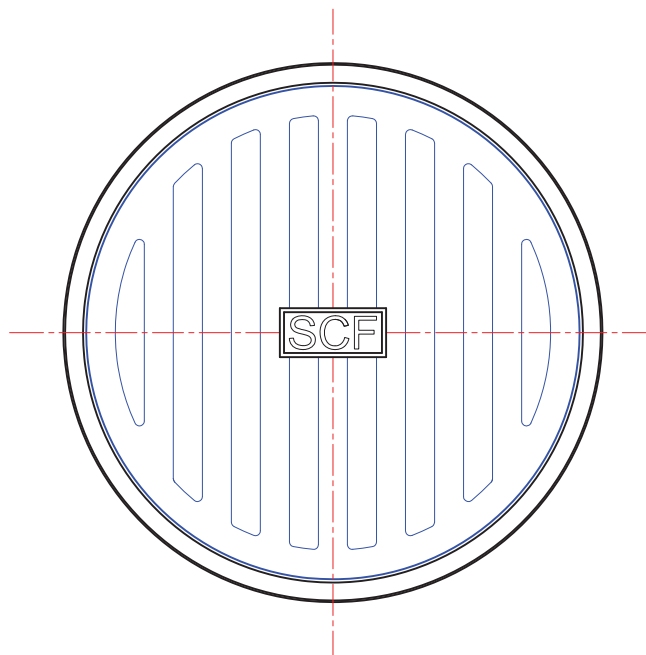

Item code	Clear Opening A(mm)	Over Base B(mm)	Depth C(mm)	Weight (kg)	Loading (Tons)	Standard
CG-1 (LD)	ø280	ø330	30	11	3	EN124

ALL WEIGHTS ARE SUBJECT TO ± 5%

(IF IN DOUBT, PLEASE ASK)

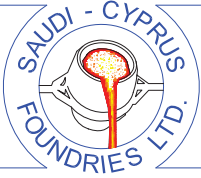

ITEM CATEGORY: GRATINGS AND FRAMES

ITEM DESCRIPTION: CIRCULAR GRATING AND FRAME

Multi duty cast iron
 grating and frame.

Options:
 Mud basket installation
 on heavy duty.

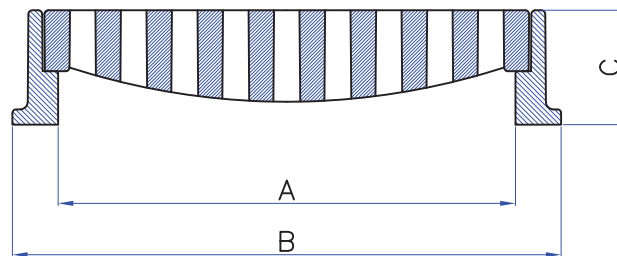
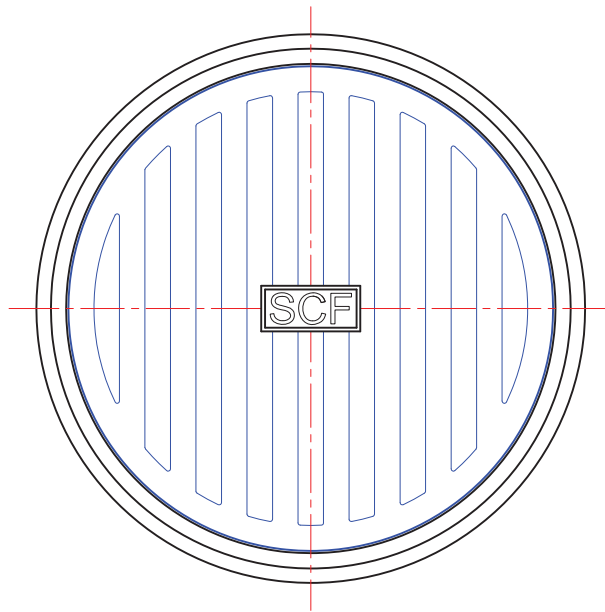

Item code	Clear Opening A(mm)	Over Base B(mm)	Depth C(mm)	Weight (kg)	Loading (Tons)	Standard
CG-2 (LD)	ø600	ø720	75	70	1	EN124
CG-2 (MD)	ø600	ø720	75	95	15	EN124
CG-2 (HD)	ø600	ø720	150	225	35	EN124

ALL WEIGHTS ARE SUBJECT TO ± 5%

(IF IN DOUBT, PLEASE ASK)

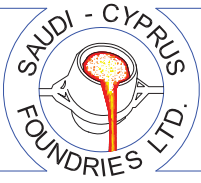

GRATINGS AND FRAMES

SQUARE GRATINGS AND FRAMES

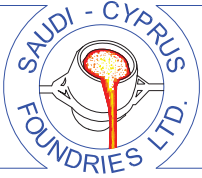

شركة المصنع السعودي القبرصي لسبك و تشكيل المعادن المحدودة
SAUDI CYPRUS FOUNDRIES LTD.

ITEM CATEGORY: GRATINGS AND FRAMES

ITEM DESCRIPTION: SQUARE GRATING AND FRAME

Light duty cast iron
 grating and frame.

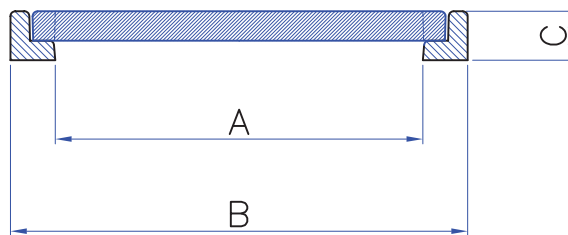
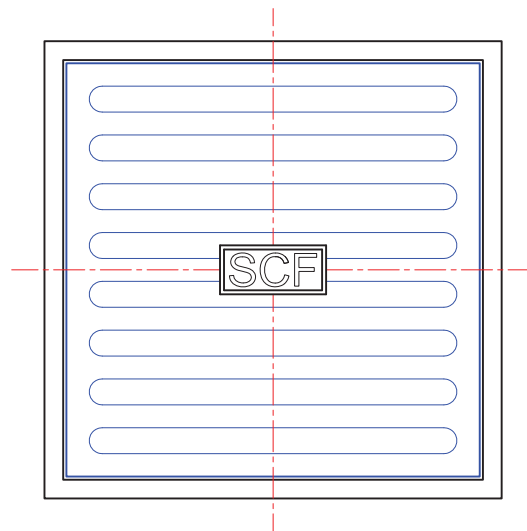

Item code	Clear Opening A(mm)	Over Base B(mm)	Depth C(mm)	Weight (kg)	Loading (Tons)	Standard
SG-1 (LD)	225sq	280sq	30	9	1	EN124

ALL WEIGHTS ARE SUBJECT TO $\pm 5\%$

(IF IN DOUBT, PLEASE ASK)

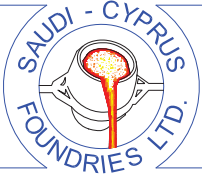

شركة المصنع السعودي القبرصي لسبك و تشكيل المادن المحدودة
SAUDI CYPRUS FOUNDRIES LTD.

ITEM CATEGORY: GRATINGS AND FRAMES

ITEM DESCRIPTION: SQUARE GRATING AND FRAME

Multi duty
 Cast iron grating
 and frame.

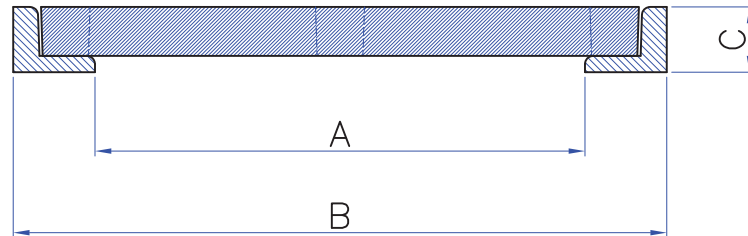
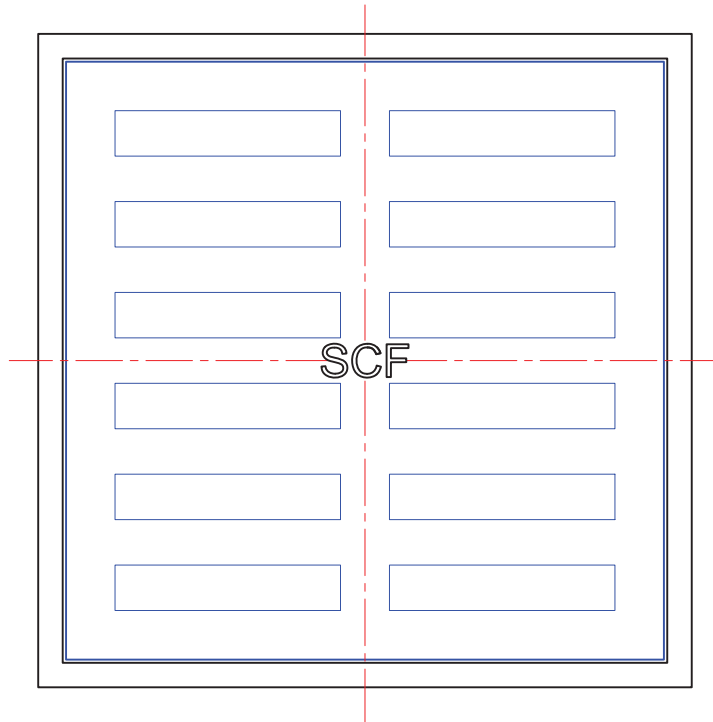

Item code	Clear Opening A(mm)	Over Base B(mm)	Depth C(mm)	Weight (kg)	Loading (Tons)	Standard
SG-2 (MD)	300sq	400sq	40	30	15	EN124

ALL WEIGHTS ARE SUBJECT TO ± 5%

(IF IN DOUBT, PLEASE ASK)

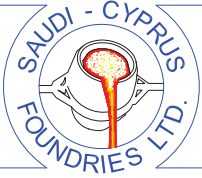

ITEM CATEGORY: GRATINGS AND FRAMES

ITEM DESCRIPTION: SQUARE GRATING AND FRAME

Multi duty
 square dished grating
 with circular clear
 opening.

Features:
 Anti skid surface.

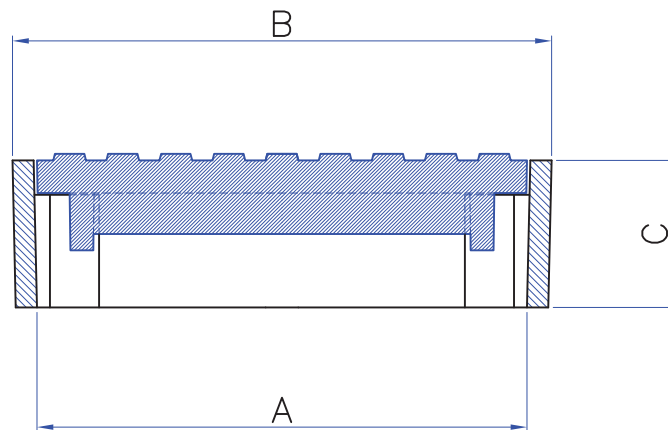
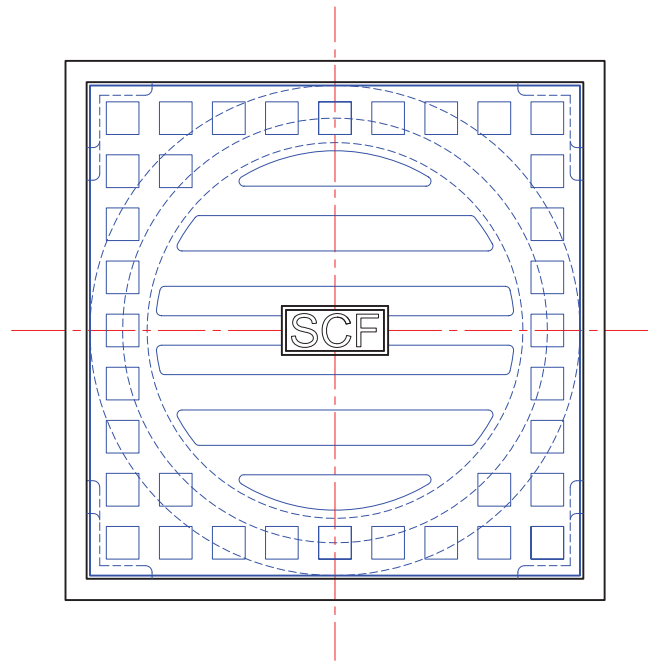

Item code	Clear Opening A(mm)	Over Base B(mm)	Depth C(mm)	Weight (kg)	Loading (Tons)	Standard
SG-3 (MD)	ø300	330sq	90	25	15	EN124

ALL WEIGHTS ARE SUBJECT TO ± 5%

(IF IN DOUBT, PLEASE ASK)

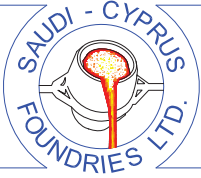

ITEM CATEGORY: GRATINGS AND FRAMES

ITEM DESCRIPTION: SQUARE GRATING AND FRAME

Heavy
 Medium duty Cast iron
 grating and frame.

Options:
 Available in heavy duty
 Double triangular.

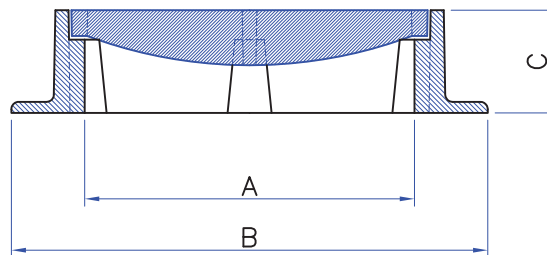
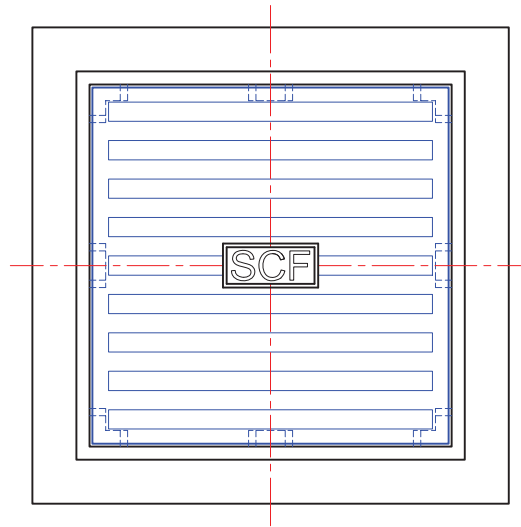

Item code	Clear Opening A(mm)	Over Base B(mm)	Depth C(mm)	Weight (kg)	Loading (Tons)	Standard
SG-4 (MD)	450sq	650sq	140	110	15	EN124
SG-4 (HD)	450sq	650sq	140	150	35	EN124

ALL WEIGHTS ARE SUBJECT TO $\pm 5\%$

(IF IN DOUBT, PLEASE ASK)

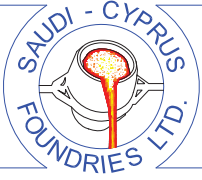

شركة المصنع السعودي القبرصي لسبك و تشكيل المعادن المحدودة
SAUDI CYPRUS FOUNDRIES LTD.

ITEM CATEGORY: GRATINGS AND FRAMES

ITEM DESCRIPTION: SQUARE GRATING AND FRAME

Heavy duty Cast iron
 grating and frame.

Features:
 Double triangular.
 Three point
 suspension.

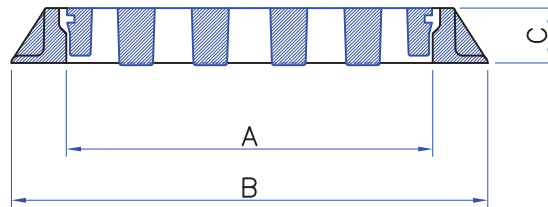
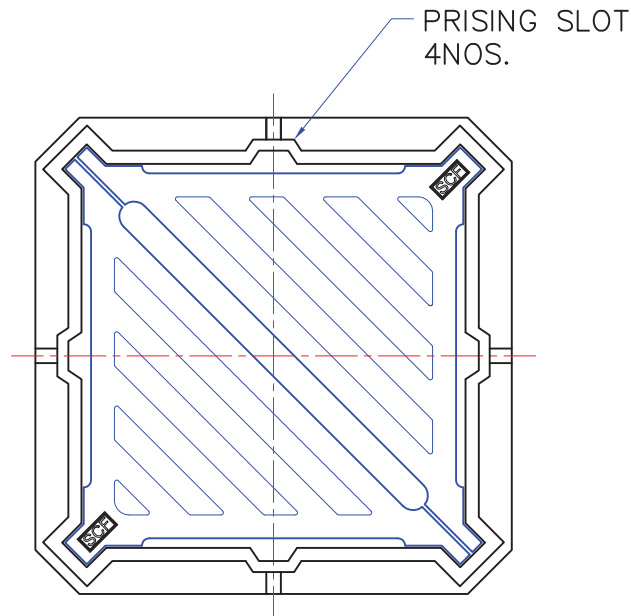

Item code	Clear Opening A(mm)	Over Base B(mm)	Depth C(mm)	Weight (kg)	Loading (Tons)	Standard
SG-5 (LD)	500sq	650sq	75	125	35	EN124

ALL WEIGHTS ARE SUBJECT TO ± 5%

(IF IN DOUBT, PLEASE ASK)

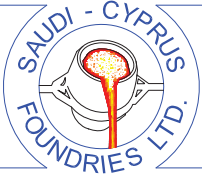

ITEM CATEGORY: GRATINGS AND FRAMES

ITEM DESCRIPTION: SQUARE GRATING AND FRAME

Heavy,
 Medium duty Cast iron
 grating and frame.

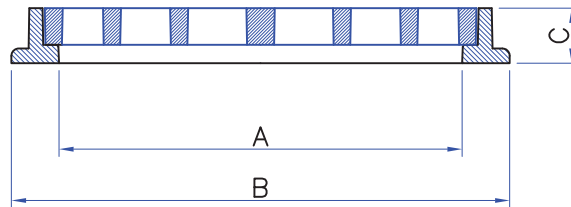
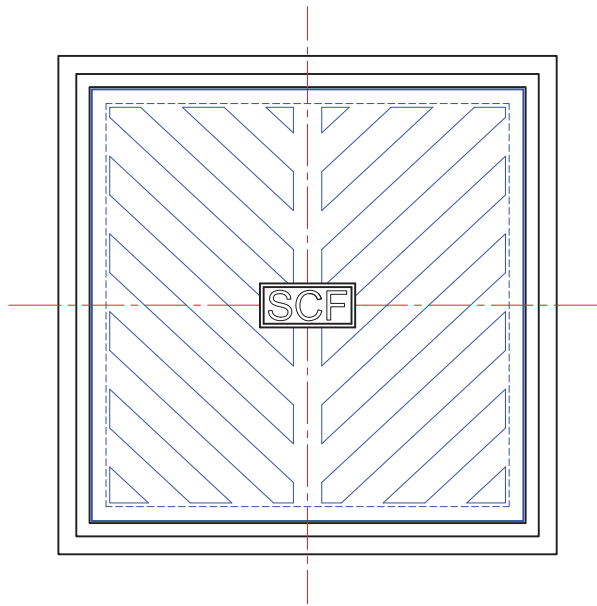

Item code	Clear Opening A(mm)	Over Base B(mm)	Depth C(mm)	Weight (kg)	Loading (Tons)	Standard
SG-6 (MD)	550sq	680sq	75	110	15	EN124
SG-6 (HD)	550sq	680sq	100	150	35	EN124

ALL WEIGHTS ARE SUBJECT TO $\pm 5\%$

(IF IN DOUBT, PLEASE ASK)

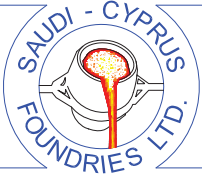

شركة المصنع السعودي القبرصي لسبك و تشكيل المعادن المحدودة
SAUDI CYPRUS FOUNDRIES LTD.

ITEM CATEGORY: GRATINGS AND FRAMES

ITEM DESCRIPTION: SQUARE GRATING AND FRAME

Light and Heavy Duty
 Cast iron
 Grating and frame.

Features:
 Mild steel hinge.

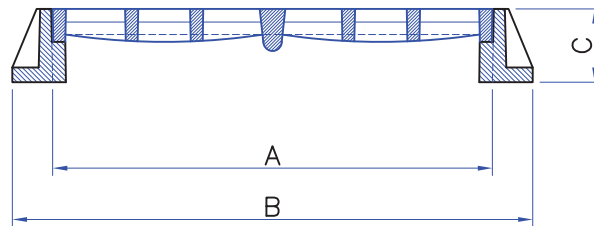
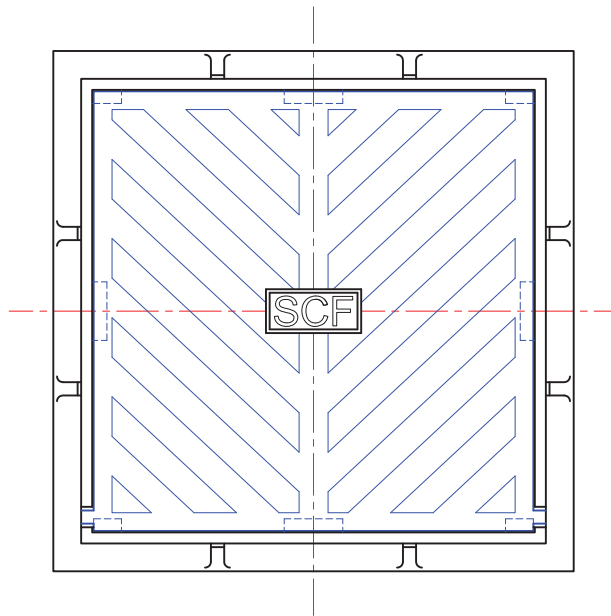

Item code	Clear Opening A(mm)	Over Base B(mm)	Depth C(mm)	Weight (kg)	Loading (Tons)	Standard
SG-7 (LD)	600sq	710sq	50	110	5	EN124
SG-7 (HD)	600sq	710sq	150	170	25	EN124

ALL WEIGHTS ARE SUBJECT TO $\pm 5\%$

(IF IN DOUBT, PLEASE ASK)

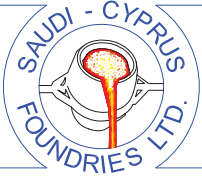

شركة المصنع السعودي القبرصي لسبك و تشكيل المعادن المحدودة
SAUDI CYPRUS FOUNDRIES LTD.

ITEM CATEGORY: GRATINGS AND FRAMES

ITEM DESCRIPTION: SQUARE GRATING AND FRAME

Heavy duty Cast iron
grating and frame.

Options:
Mud basket
installation.

Features:
Locking device.
Mild steel hinge.

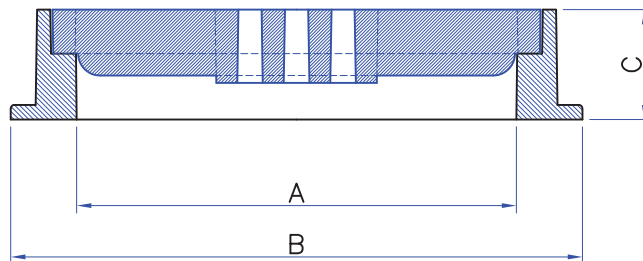
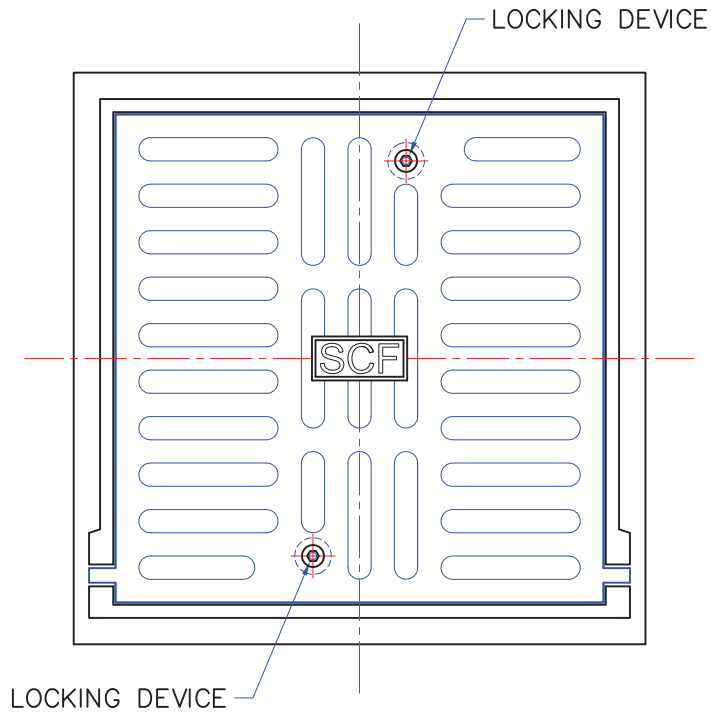

Item code	Clear Opening A(mm)	Over Base B(mm)	Depth C(mm)	Weight (kg)	Loading (Tons)	Standard
SG-8 (HD)	600sq	780sq	150	250	40	EN124

ALL WEIGHTS ARE SUBJECT TO $\pm 5\%$

(IF IN DOUBT, PLEASE ASK)

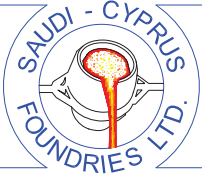

ITEM CATEGORY: GRATINGS AND FRAMES

ITEM DESCRIPTION: SQUARE GRATING AND FRAME

Heavy duty Cast iron
 Grating and frame.

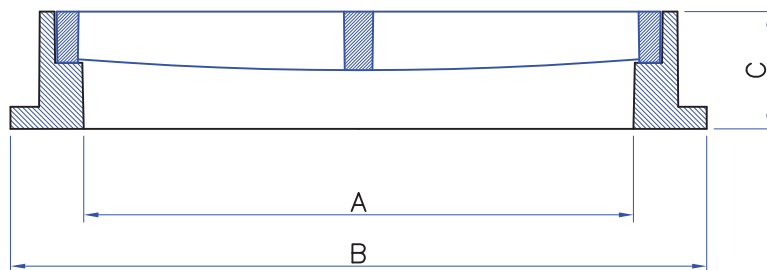
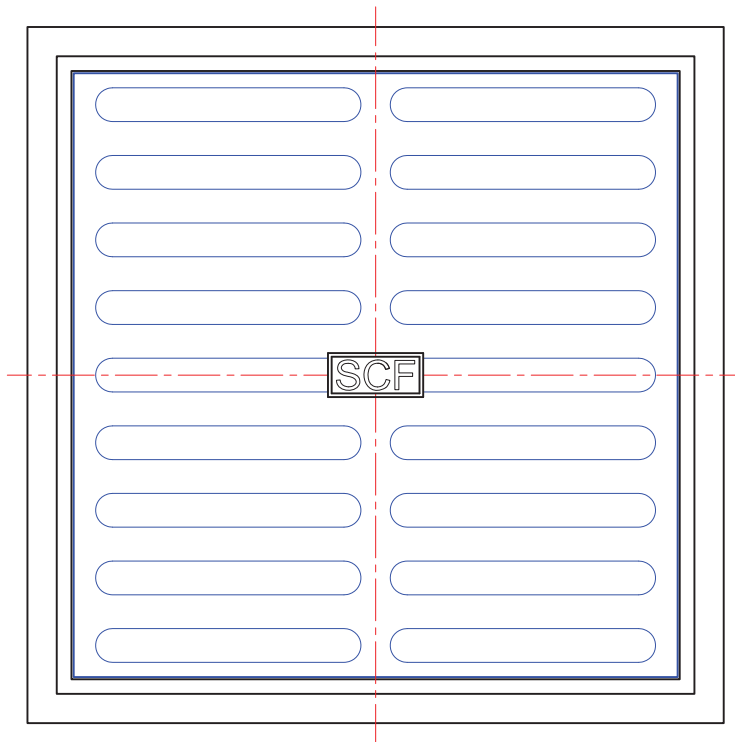

Item code	Clear Opening A(mm)	Over Base B(mm)	Depth C(mm)	Weight (kg)	Loading (Tons)	Standard
SG-9 (HD)	750sq	950sq	160	400	40	EN124
SG-10 (HD)	800sq	1000sq	160	470	40	EN124

ALL WEIGHTS ARE SUBJECT TO ± 5%

(IF IN DOUBT, PLEASE ASK)

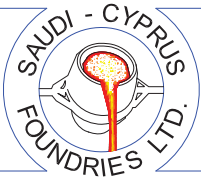

GRATINGS AND FRAMES

RECTANGULAR GRATINGS AND FRAMES

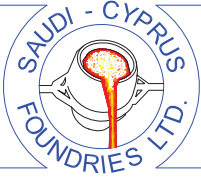

شركة المصنع السعودي القبرصي لسبك و تشكيل المعادن المحدودة
SAUDI CYPRUS FOUNDRIES LTD.

ITEM CATEGORY: GRATINGS AND FRAMES

ITEM DESCRIPTION: RECTANGULAR GRATING AND FRAME

Medium duty Cast iron
 grating and frame

Options:
 Gully chute connector.

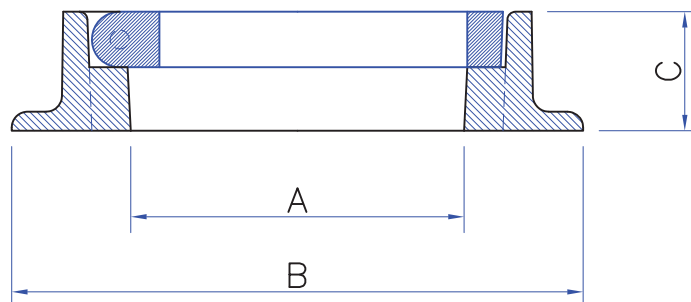
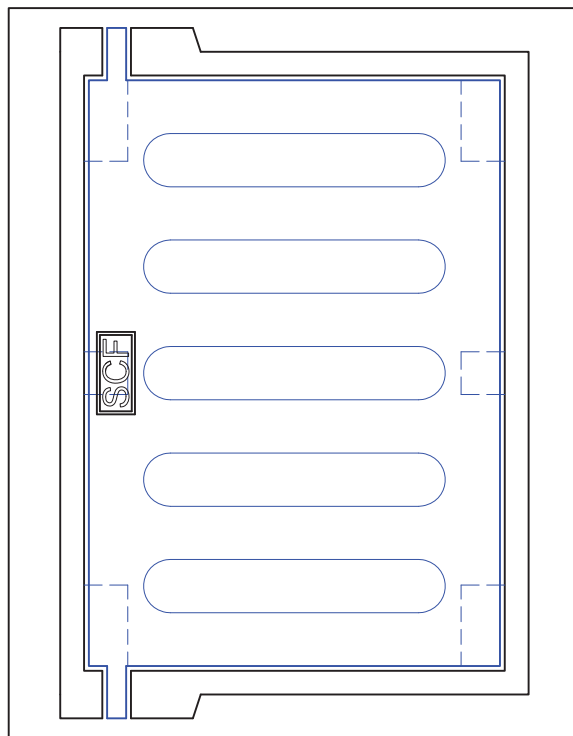

Item code	Clear Opening A(mm)	Over Base B(mm)	Depth C(mm)	Weight (kg)	Loading (Tons)	Standard
RG-1 (MD)	320x210	460x360	75	40	15	EN124
RG-2 (MD)	410x300	600x480	150	110	15	EN124

ALL WEIGHTS ARE SUBJECT TO $\pm 5\%$

(IF IN DOUBT, PLEASE ASK)

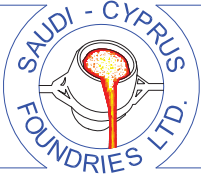

شركة المصنع السعودي القبرصي لسبك و تشكيل المعادن المحدودة
SAUDI CYPRUS FOUNDRIES LTD.

ITEM CATEGORY: GRATINGS AND FRAMES

ITEM DESCRIPTION: RECTANGULAR GRATING AND FRAME

Heavy duty Cast iron
 grating and frame.

Features:
 Mild steel hinge.

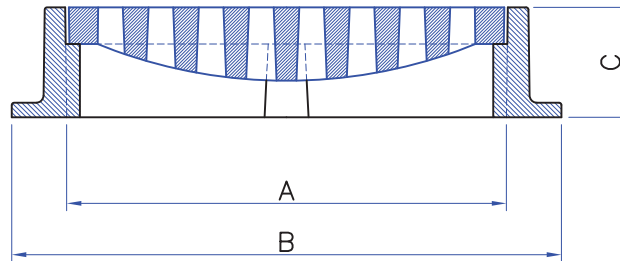
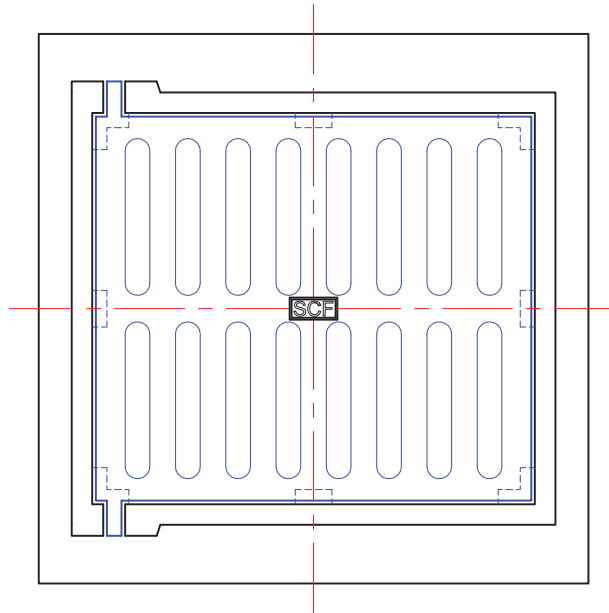

Item code	Clear Opening A(mm)	Over Base B(mm)	Depth C(mm)	Weight (kg)	Loading (Tons)	Standard
RG-3	600x530	750sq	150	215	25	EN124

ALL WEIGHTS ARE SUBJECT TO $\pm 5\%$

(IF IN DOUBT, PLEASE ASK)

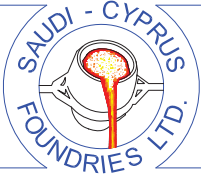

شركة المصنع السعودي القبرصي لسبك و تشكيل المعادن المحدودة
SAUDI CYPRUS FOUNDRIES LTD.

ITEM CATEGORY: GRATINGS AND FRAMES

ITEM DESCRIPTION: RECTANGULAR GRATING AND FRAME

Multi duty, straight bars
 Cast iron Channel grating
 and mild steel angle frames.

Features:
 Standard length – 750mm.
 Standard depth – 54mm.

Options:
 Anchoring.

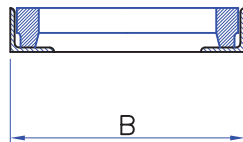
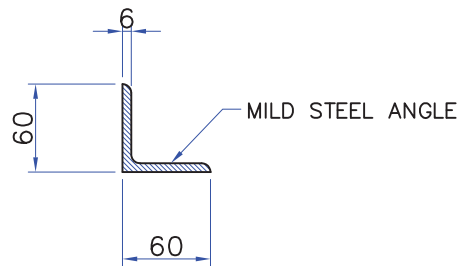
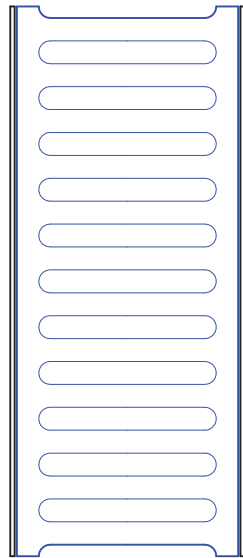

Item code	Over Base B(mm)	Weight (kg)	Loading (Tons)	Standard
RG-4 (LD)	165	27	1	EN124
RG-4 (MD)	165	30	15	EN124
RG-4 (HD)	165	35	35	EN124
RG-5 (LD)	215	30	1	EN124
RG-5 (MD)	215	33	15	EN124
RG-5 (HD)	215	35	35	EN124
RG-6 (LD)	265	30	1	EN124
RG-6 (MD)	265	35	15	EN124
RG-6 (HD)	265	43	35	EN124

ALL WEIGHTS ARE SUBJECT TO ± 5%

(IF IN DOUBT, PLEASE ASK)

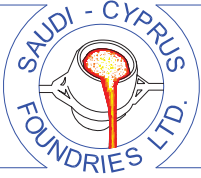

شركة المصنع السعودي القبرصي لسبك و تشكيل المعادن المحدودة
SAUDI CYPRUS FOUNDRIES LTD.

ITEM CATEGORY: GRATINGS AND FRAMES

ITEM DESCRIPTION: RECTANGULAR GRATING AND FRAME

Multi duty, straight bars
 Cast iron Channel grating
 and mild steel angle frames.

Features:
 Standard length – 750mm.
 Standard depth – 54mm.

Options:
 Anchoring.

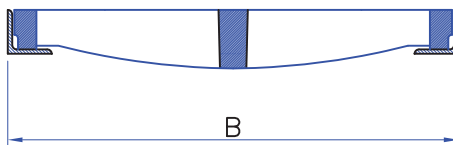
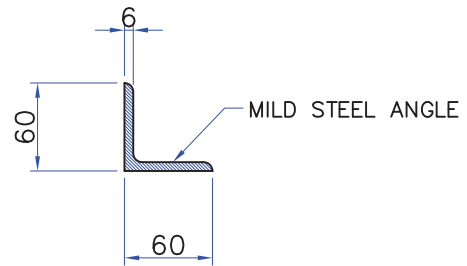
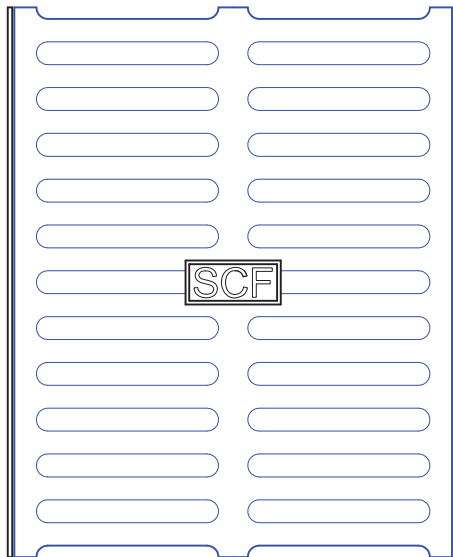

Item code	Over Base B(mm)	Weight (kg)	Loading (Tons)	Standard
RG-7 (LD)	515	60	1	EN124
RG-7 (MD)	515	85	15	EN124
RG-7 (HD)	515	105	35	EN124
RG-8 (LD)	615	65	1	EN124
RG-8 (MD)	615	115	15	EN124
RG-8 (HD)	615	140	35	EN124

ALL WEIGHTS ARE SUBJECT TO ± 5%

(IF IN DOUBT, PLEASE ASK)

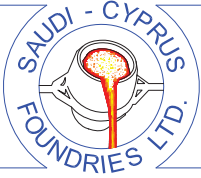

شركة المصنع السعودي القبرصي لسبك و تشكيل المعادن المحدودة
SAUDI CYPRUS FOUNDRIES LTD.

ITEM CATEGORY: GRATINGS AND FRAMES

ITEM DESCRIPTION: RECTANGULAR GRATING AND FRAME

Multi duty, straight bars
 Cast iron
 Channel grating, and sides.

Features:
 Holes for anchoring.
 Holes for jointing.
 Standard length – 750mm.

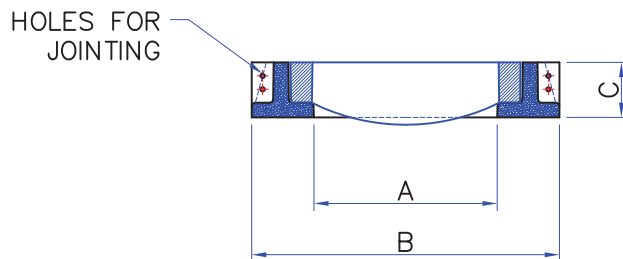
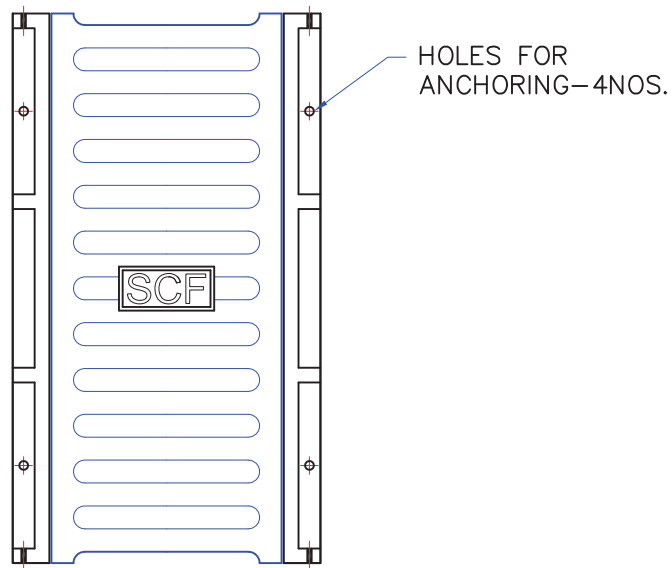

Item code	Clear Opening A(mm)	Over Base B(mm)	Depth C(mm)	Weight (kg)	Loading (Tons)	Standard
RG-9 (LD)	250	750x420	75	65	1	EN124
RG-9 (MD)	250	750x420	75	72	15	EN124
RG-9(HD)	250	750x420	75	85	35	EN124
RG-10 (LD)	350	750x520	75	78	1	EN124
RG-10 (MD)	350	750x520	75	90	15	EN124
RG-10 (HD)	350	750x520	75	105	35	EN124

ALL WEIGHTS ARE SUBJECT TO ± 5%

(IF IN DOUBT, PLEASE ASK)

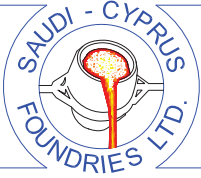

شركة المصنع السعودي القبرصي لسبك و تشكيل المعادن المحدودة
SAUDI CYPRUS FOUNDRIES LTD.

ITEM CATEGORY: GRATINGS AND FRAMES

ITEM DESCRIPTION: RECTANGULAR GRATING AND FRAME

Multi duty, straight bars
 Cast iron Channel grating
 and mild steel angle frames.

Features:
 Standard length – 750mm.
 Standard depth – 54mm.

Options:
 Anchoring.

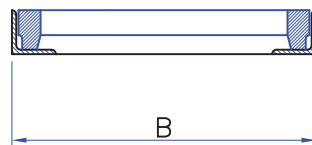
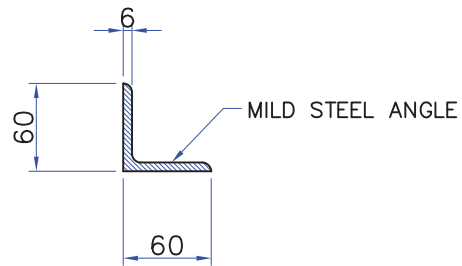
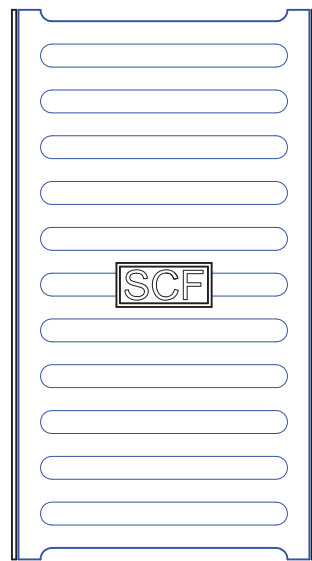

Item code	Over Base B(mm)	Weight (kg)	Loading (Tons)	Standard
RG-11 (LD)	315	35	1	EN124
RG-11 (MD)	315	40	15	EN124
RG-11 (HD)	315	55	35	EN124
RG-12 (LD)	415	45	1	EN124
RG-12 (MD)	415	55	15	EN124
RG-12 (HD)	415	75	35	EN124

ALL WEIGHTS ARE SUBJECT TO $\pm 5\%$

(IF IN DOUBT, PLEASE ASK)

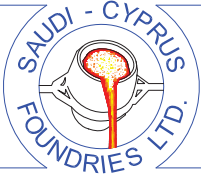

ITEM CATEGORY: GRATINGS AND FRAMES

ITEM DESCRIPTION: RECTANGULAR GRATING AND FRAME

Multi duty, straight bars
 Cast iron
 Channel grating, and sides.

Features:
 Standard length – 750mm.

Options:
 Holes for anchoring.
 Holes for jointing.

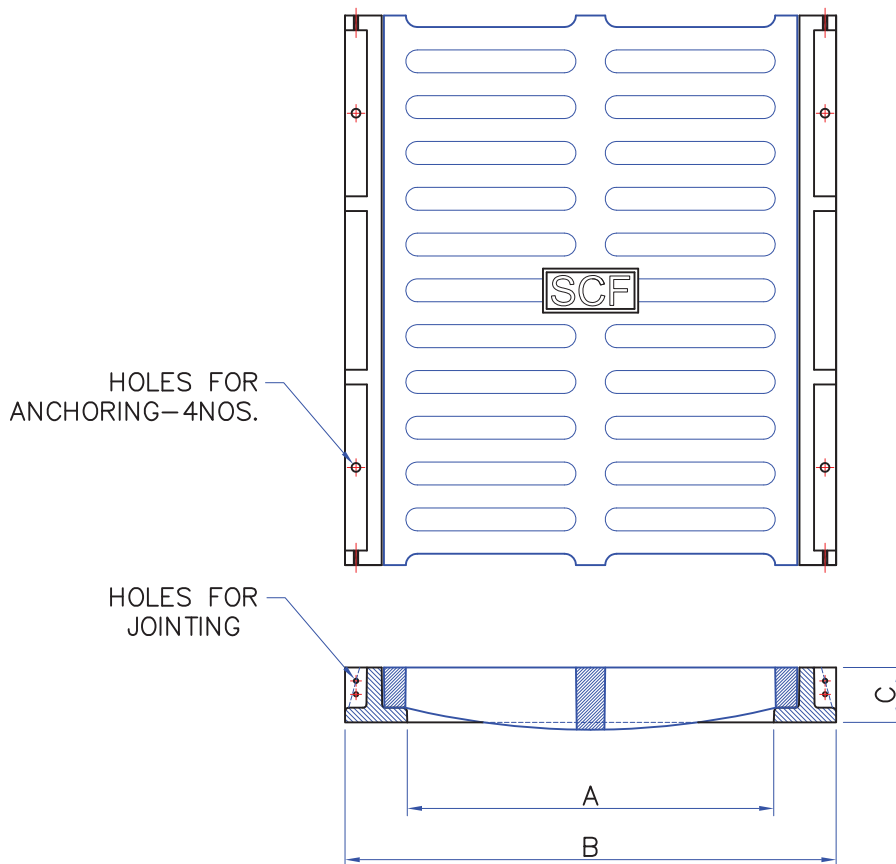

Item code	Clear Opening A(mm)	Over Base B(mm)	Depth C(mm)	Weight (kg)	Loading (Tons)	Standard
RG-13 (LD)	400	750x570	75	80	1	EN124
RG-13 (MD)	400	750x570	75	105	15	EN124
RG-13 (HD)	400	750x570	75	125	35	EN124
RG-14 (LD)	500	750x670	75	95	1	EN124
RG-14 (MD)	500	750x670	75	125	15	EN124
RG-14 (HD)	500	750x670	75	155	35	EN124
RG-15 (LD)	600	750x770	75	125	1	EN124
RG-15 (MD)	600	750x770	75	155	15	EN124
RG-15 (HD)	600	750x770	75	175	35	EN124

ALL WEIGHTS ARE SUBJECT TO ± 5%

(IF IN DOUBT, PLEASE ASK)

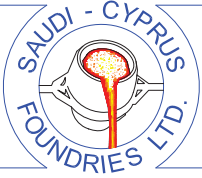

ITEM CATEGORY: GRATINGS AND FRAMES

ITEM DESCRIPTION: RECTANGULAR GRATING AND FRAME

Heavy duty Cast iron
 Grating and frame.

Features:
 Double grating and
 Single frame.

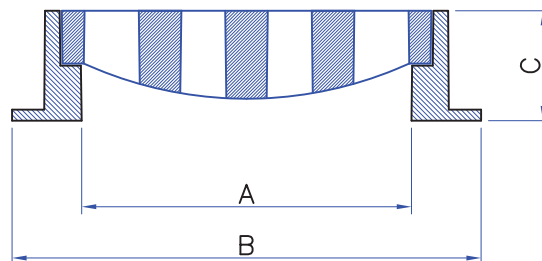
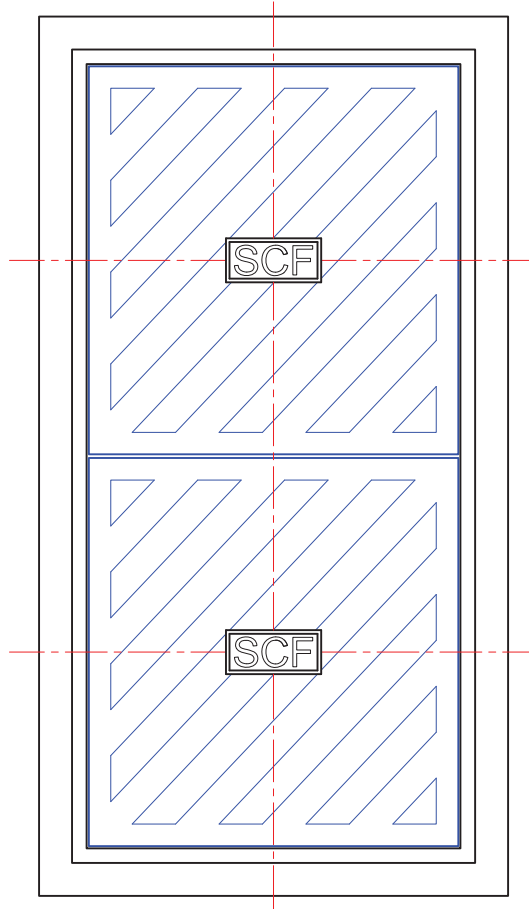

Item code	Clear Opening A(mm)	Over Base B(mm)	Depth C(mm)	Weight (kg)	Loading (Tons)	Standard
RG-16 (HD)	1010x450	1200x640	150	350	25	EN124

ALL WEIGHTS ARE SUBJECT TO $\pm 5\%$

(IF IN DOUBT, PLEASE ASK)

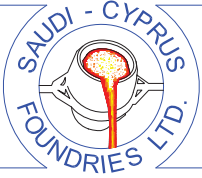

شركة المصنع السعودي القبرصي لسبك و تشكيل المعادن المحدودة
SAUDI CYPRUS FOUNDRIES LTD.

ITEM CATEGORY: GRATINGS AND FRAMES

ITEM DESCRIPTION: RECTANGULAR GRATE AND FRAME

Multi dutyCast iron
 grating and frame.

Features:
 Double grating and
 Single frame.

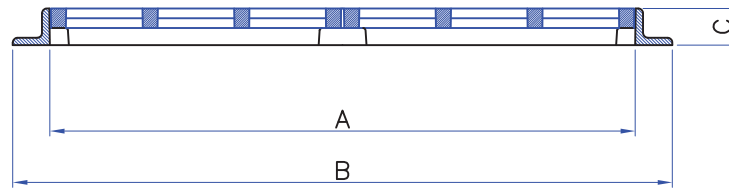
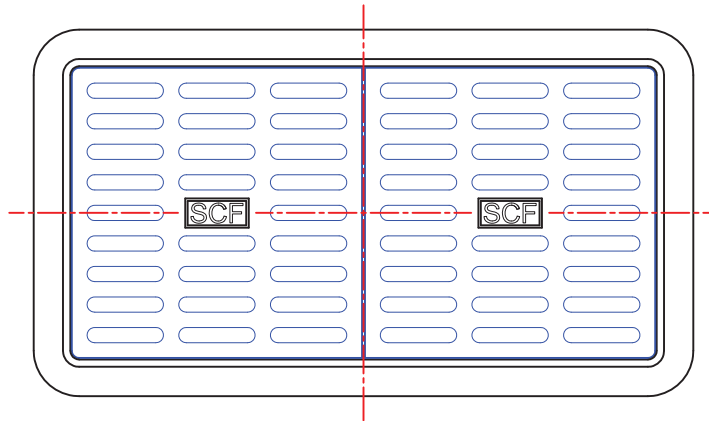

Item code	Clear Opening A(mm)	Over Base B(mm)	Depth C(mm)	Weight (kg)	Loading (Tons)	Standard
RG-17 (LD)	1200x600	1350x750	75	180	3	EN124

ALL WEIGHTS ARE SUBJECT TO $\pm 5\%$

(IF IN DOUBT, PLEASE ASK)

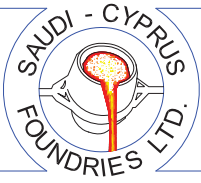

شركة المصنع السعودي القبرصي لسبك و تشكيل المعادن المحدودة
SAUDI CYPRUS FOUNDRIES LTD.

GRATINGS AND FRAMES

GARDEN GRATINGS

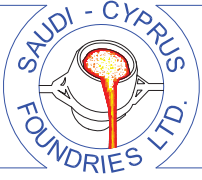

شركة المصنع السعودي القبرصي لسبك و تشكيل المادن المحدودة
SAUDI CYPRUS FOUNDRIES LTD.

ITEM CATEGORY: CAST IRON GARDEN GRATINGS

ITEM DESCRIPTION: TREE GRATING

Cast iron
 Square tree grating.

Features:
 Grate in two pieces.
 Grate bolted together.
 Tree opening – 320 sq.mm.

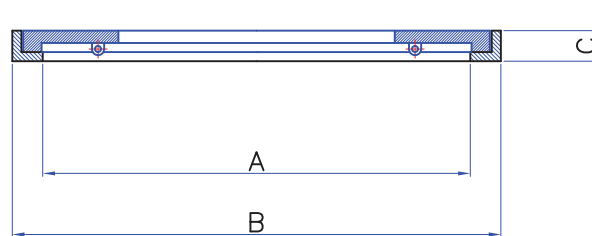
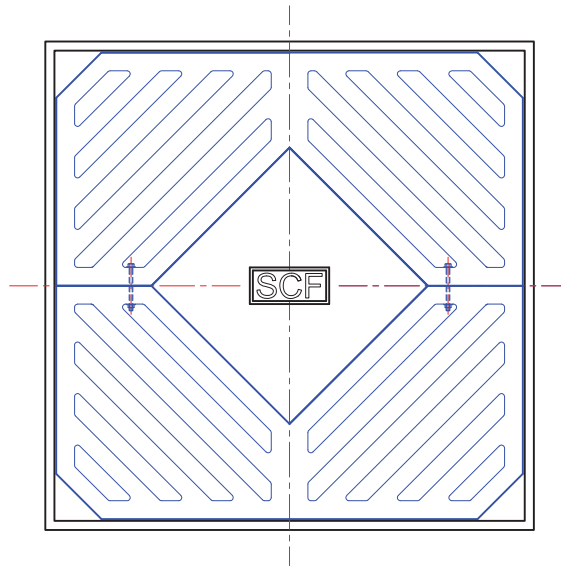

Item code	Clear Opening A(mm)	Over Base B(mm)	Depth C(mm)	Weight (kg)
TG-1	700sq	800sq	50	86

ALL WEIGHTS ARE SUBJECT TO ± 5%

(IF IN DOUBT, PLEASE ASK)

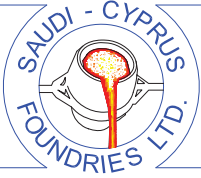

شركة المصنع السعودي القبرصي لسبك و تشكيل المادن المحدودة
SAUDI CYPRUS FOUNDRIES LTD.

ITEM CATEGORY: CAST IRON GARDEN GRATINGS

ITEM DESCRIPTION: TREE GRATING

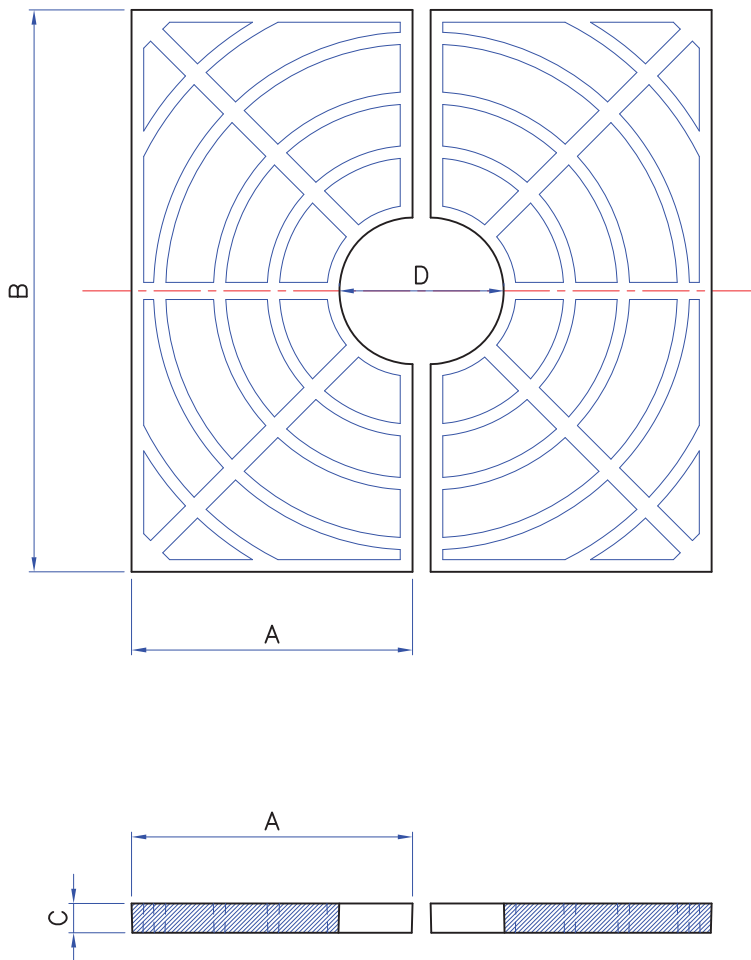

Item code	Width A(mm)x2	Lenght B(mm)	Depth C(mm)	Weight (kg)	Tree Opening D(mm)	Standard
TG-2	1200	1150	30	200	ø300	EN124

ALL WEIGHTS ARE SUBJECT TO ± 5%

(IF IN DOUBT, PLEASE ASK)

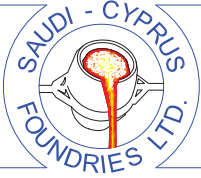

ITEM CATEGORY: CAST IRON GARDEN GRATINGS

ITEM DESCRIPTION: TREE GRATING

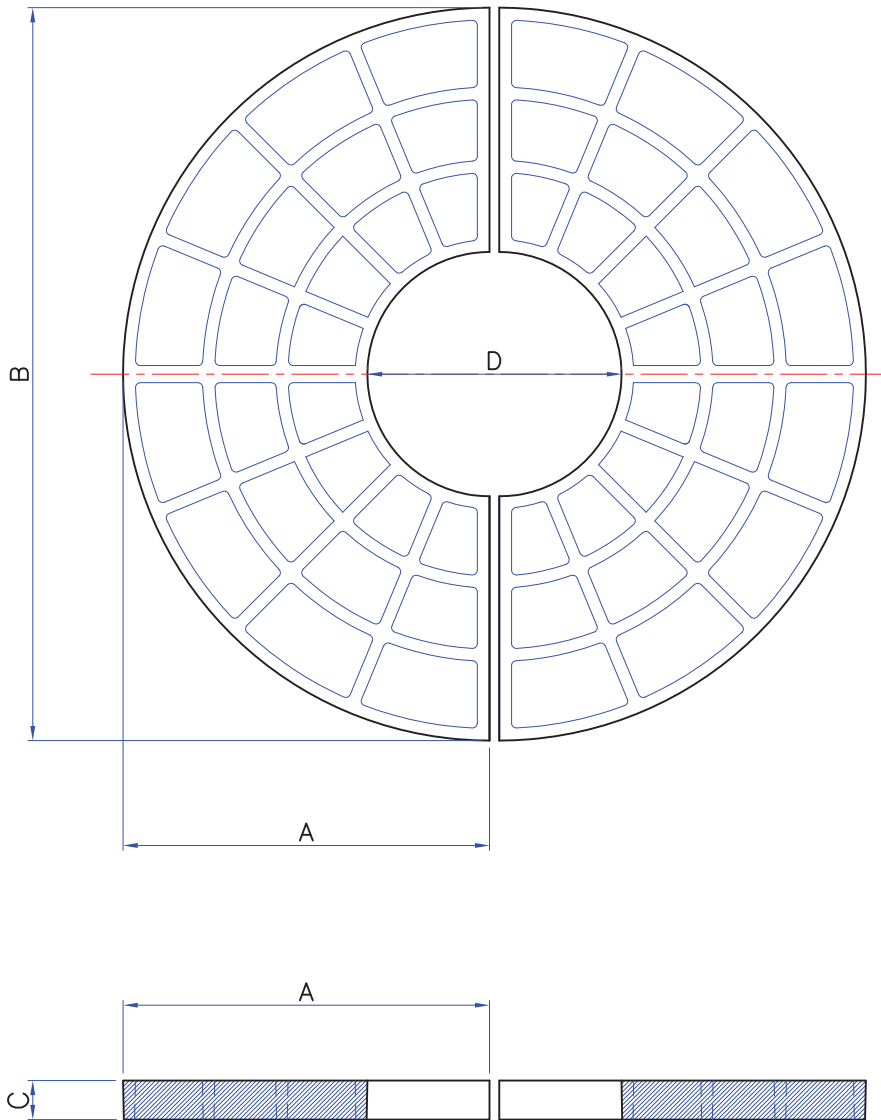

Item code	Width A(mm)x2	Lenght B(mm)	Depth C(mm)	Weight (kg)	Tree Opening D(mm)	Standard
TG-3	1500	1500	40	400	ø500	EN124

ALL WEIGHTS ARE SUBJECT TO ± 5%

(IF IN DOUBT, PLEASE ASK)

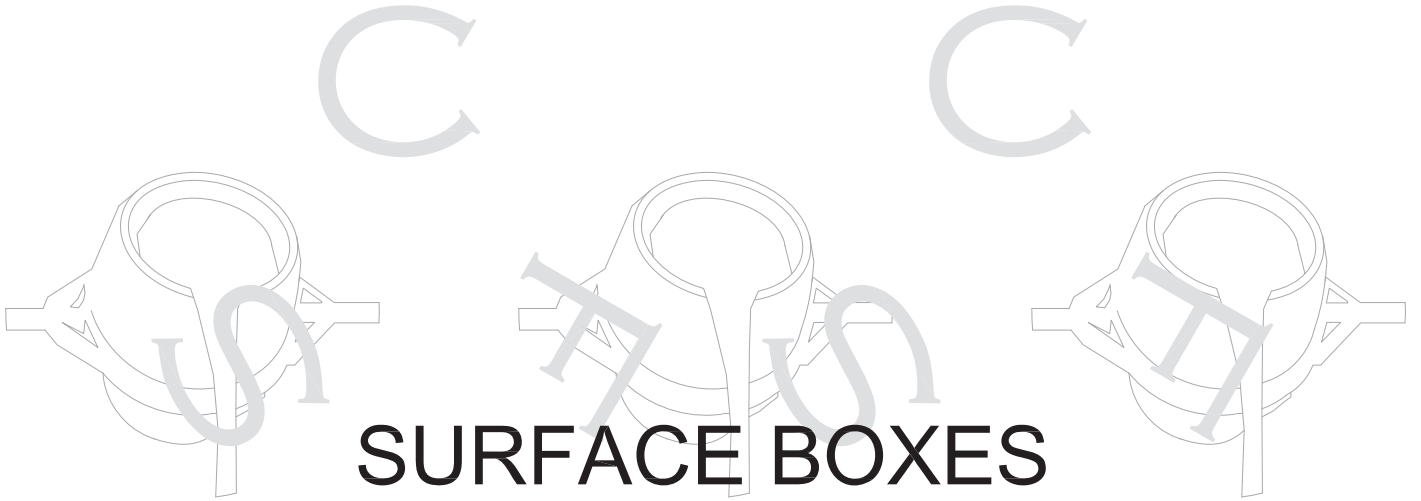
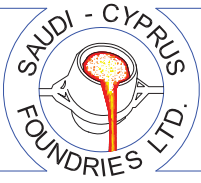

SURFACE BOXES

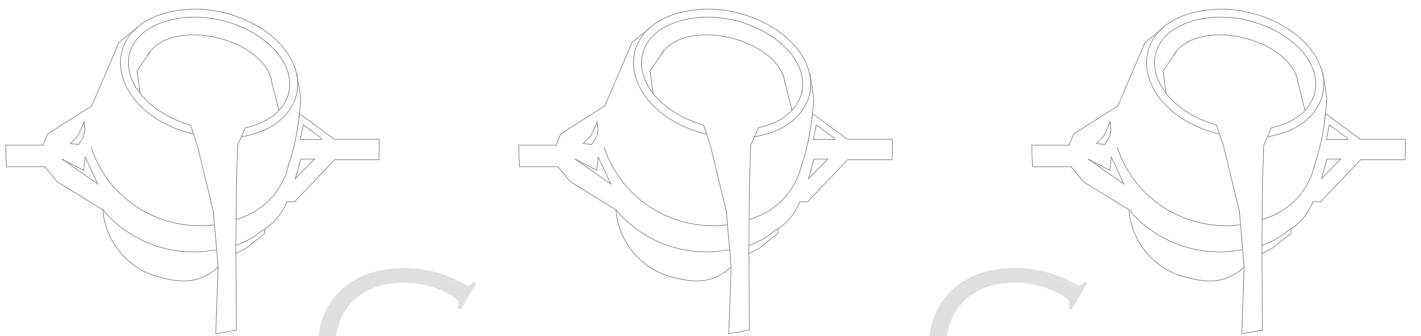

SURFACE BOX

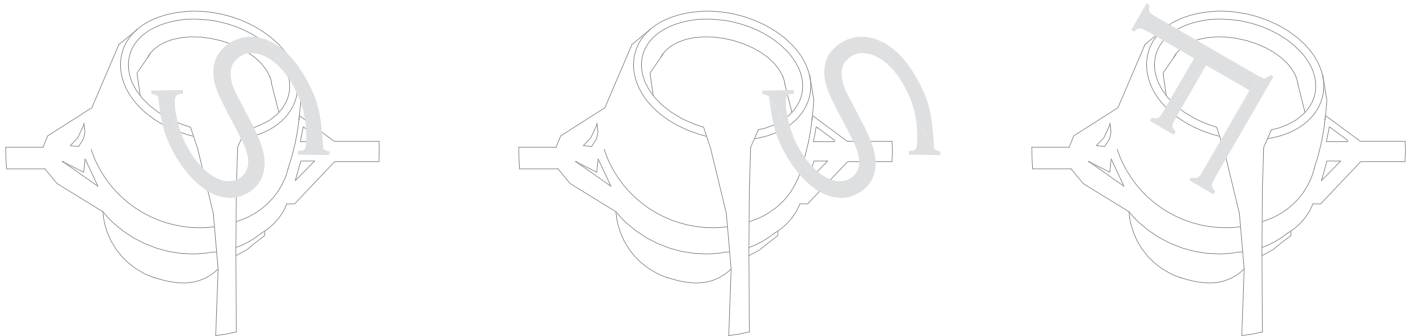

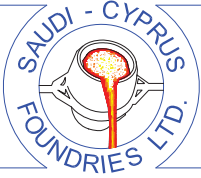

ITEM CATEGORY: SURFACE BOXES

ITEM DESCRIPTION: SURFACE BOX

Heavy duty cast iron surface box.

Features:
 Securing rod.
 Lifting handle.

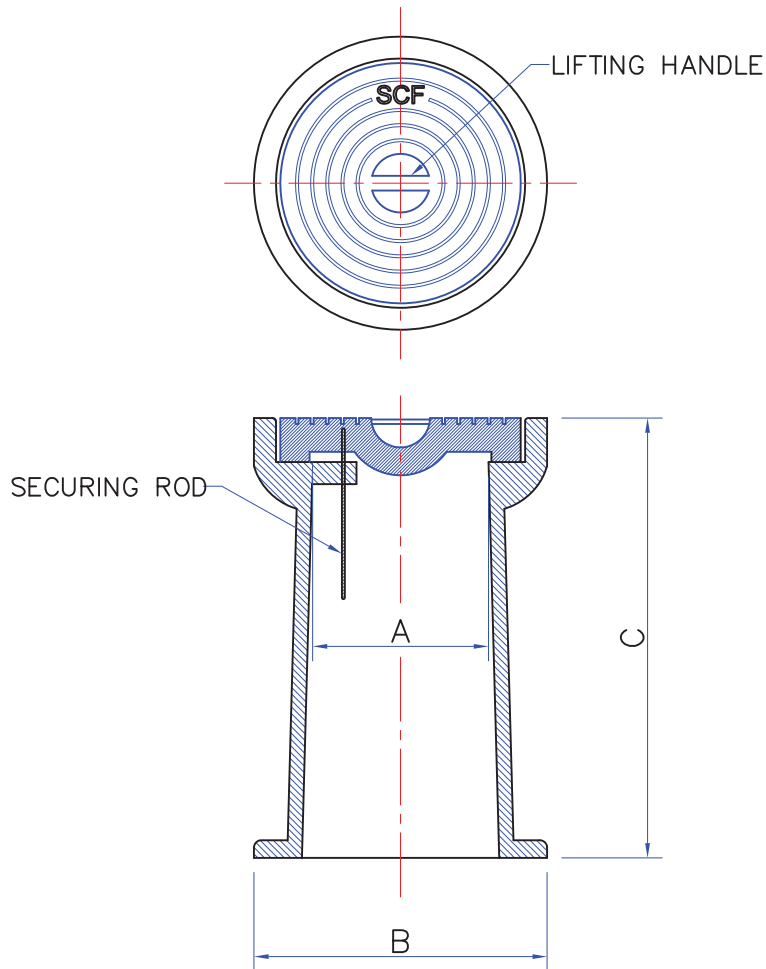

Item code	Clear Opening A(mm)	Over Base B(mm)	Depth (mm)	Weight (kg)
SB-1	ø120	ø200	300	15

ALL WEIGHTS ARE SUBJECT TO ± 5%

(IF IN DOUBT, PLEASE ASK)

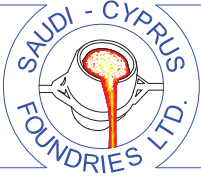

شركة المصنع السعودي القبرصي لسبك و تشكيل المعادن المحدودة
SAUDI CYPRUS FOUNDRIES LTD.

ITEM CATEGORY: SURFACE BOXES

ITEM DESCRIPTION: SURFACE BOX

Heavy duty cast iron surface box.

Features:
 Blind keyhole.
 Non rotating cover.
 Locking device.
 Prising slot.

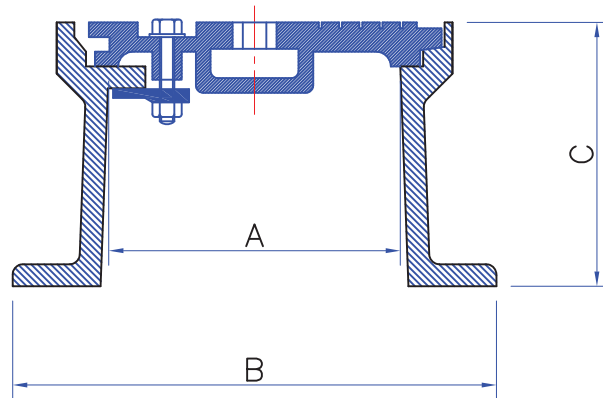
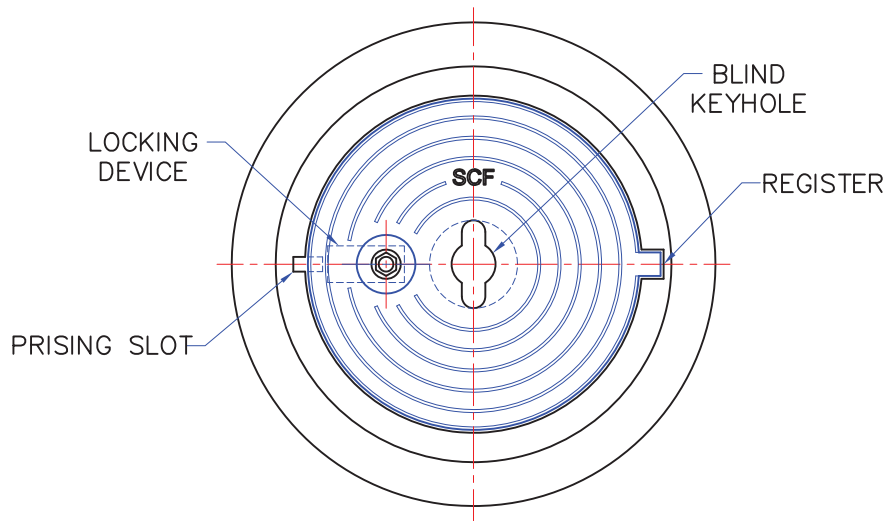

Item code	Clear Opening A(mm)	Over Base B(mm)	Depth (mm)	Weight (kg)
SB-2	ø140	ø270	180	17
SB-3	ø200	ø330	180	26

ALL WEIGHTS ARE SUBJECT TO ± 5%

(IF IN DOUBT, PLEASE ASK)

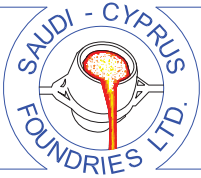

شركة المصنع السعودي القبرصي لسبك و تشكيل المعادن المحدودة
SAUDI CYPRUS FOUNDRIES LTD.

ITEM CATEGORY: SURFACE BOXES

ITEM DESCRIPTION: SURFACE BOX

Heavy duty cast iron surface box.

Features:
 Lifting handle.
 Locking device.
 Cover chained to box.
 Galvanized chain.

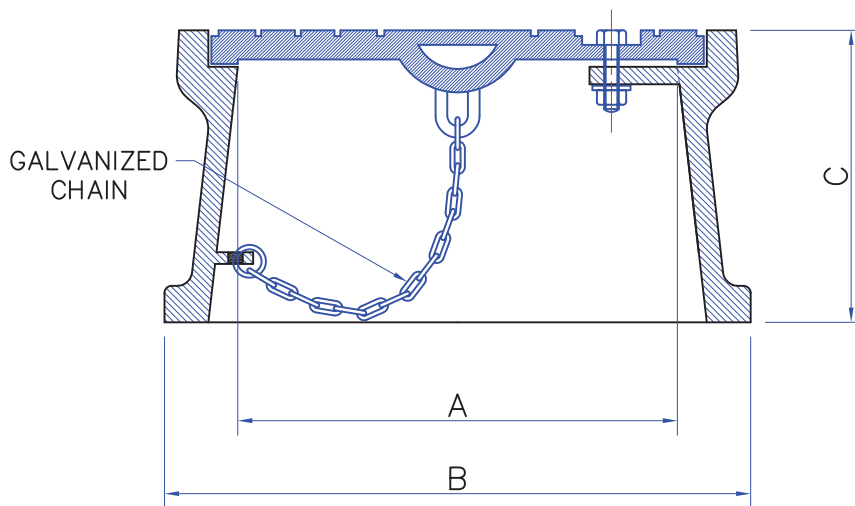
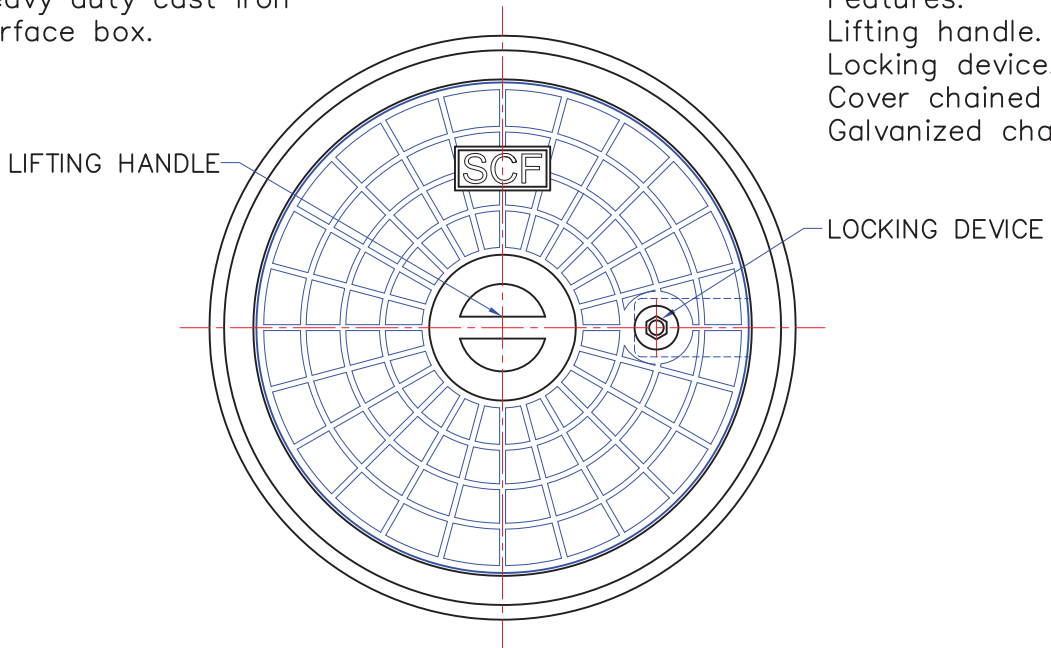

Item code	Clear Opening A(mm)	Over Base B(mm)	Depth (mm)	Weight (kg)
SB-4	ø190	ø275	135	15
SB-5	ø300	ø400	200	38

ALL WEIGHTS ARE SUBJECT TO ± 5%

(IF IN DOUBT, PLEASE ASK)

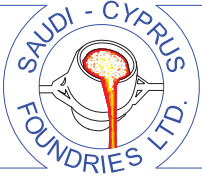

شركة المصنع السعودي القبرصي لسبك و تشكيل المعادن المحدودة
SAUDI CYPRUS FOUNDRIES LTD.

ITEM CATEGORY: SURFACE BOXES

ITEM DESCRIPTION: SURFACE BOX

Heavy duty cast iron surface box.

Features:
 Blind keyhole.
 Cover chained to box.
 Galvanized chain.

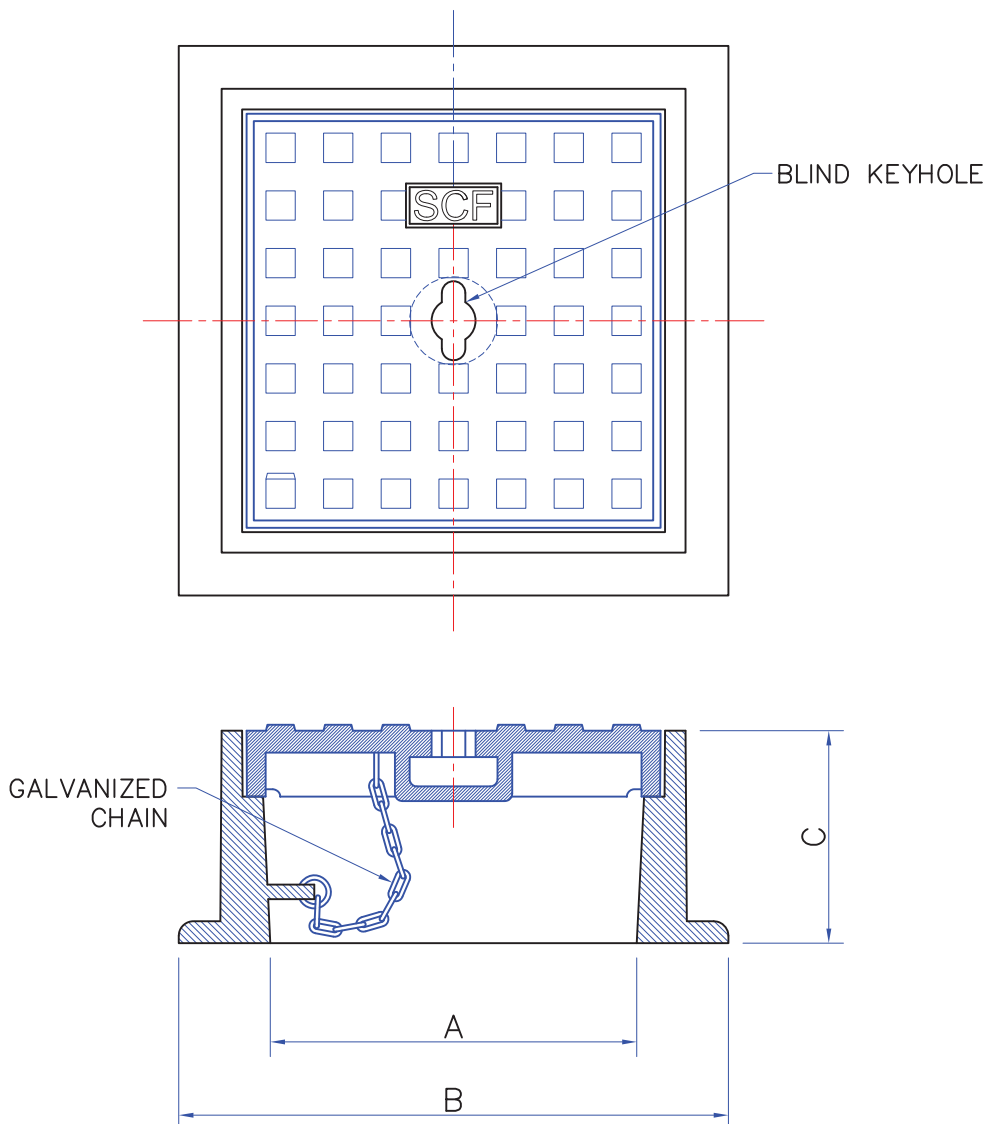

Item code	Clear Opening B(mm)	Over Base B(mm)	Depth (mm)	Weight (kg)
SB-6	250sq	375sq	145	45

ALL WEIGHTS ARE SUBJECT TO ± 5%

(IF IN DOUBT, PLEASE ASK)

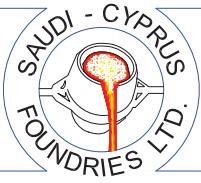

شركة المصنع السعودي القبرصي لسبك و تشكيل المعادن المحدودة
SAUDI CYPRUS FOUNDRIES LTD.

MANHOLES COVERS AND FRAMES

DUCTILE IRON CASTINGS

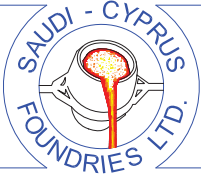

شركة المصنع السعودي القبرصي لسبك و تشكيل المادن المحدودة
SAUDI CYPRUS FOUNDRIES LTD.

ITEM CATEGORY: DUCTILE IRON MANHOLES COVERS AND FRAMES

ITEM DESCRIPTION: COVER AND FRAME HINGED TYPE

Ductile Iron in
 Accordance with
 Standards EN124

Features:
 Hinge Type.
 Blind Keyhole.
 Two Locking Device.
 One Prising Slot.
 Rubber Gasket.

Option:
 Square frame.

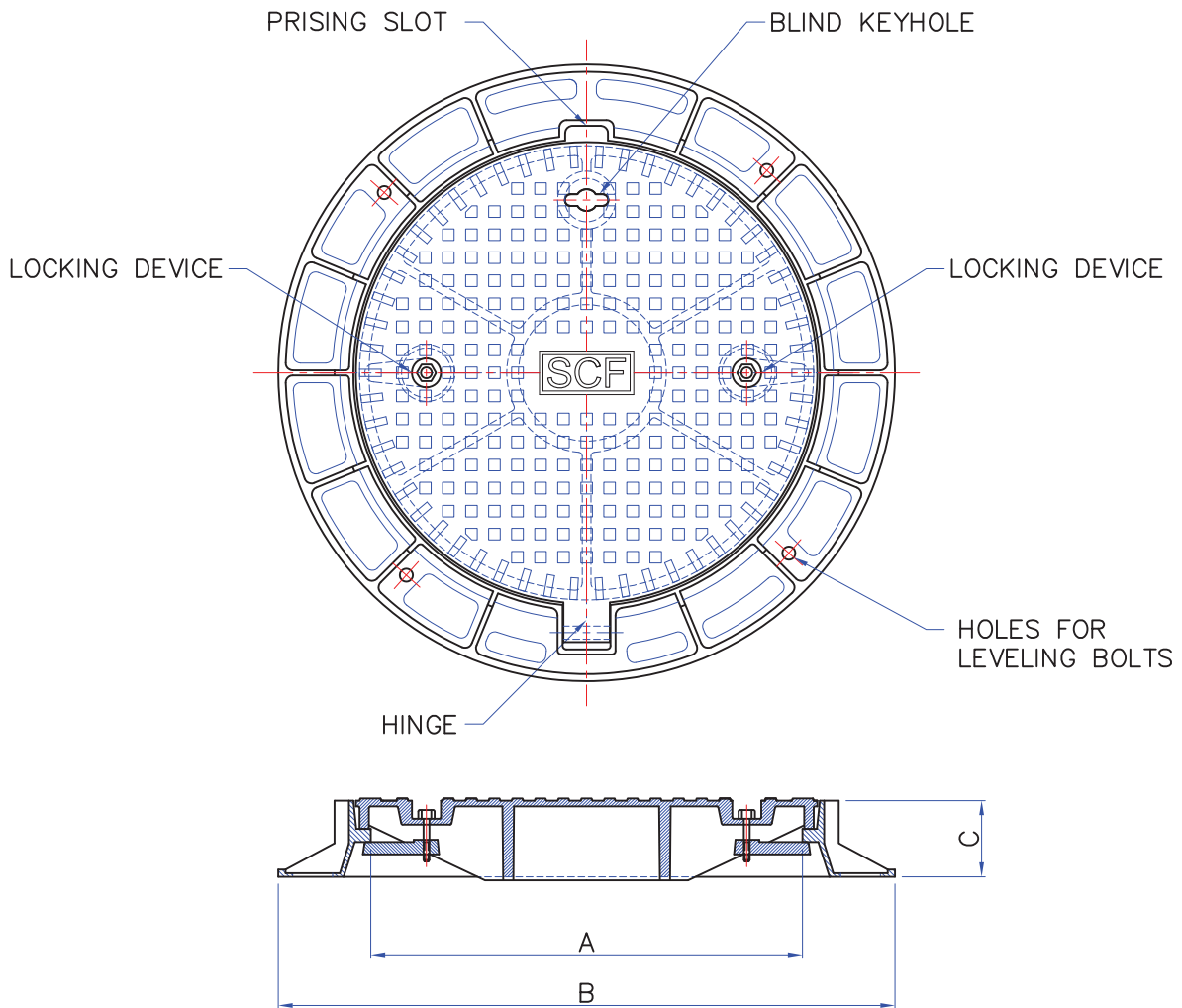

Item code	Clear Opening A(mm)	Over Base B(mm)	Depth C(mm)	Weight (kg)	Loading (Tons)	Standard
DI-502 (HD)	ø600	ø850	100	75	40	EN124
DI-2 (HD)	ø600	800x800	100	75	40	EN124

ALL WEIGHTS ARE SUBJECT TO ± 5%

(IF IN DOUBT, PLEASE ASK)

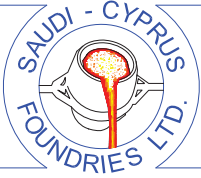

شركة المصنع السعودي القبرصي لسبك و تشكيل المادن المحدودة
SAUDI CYPRUS FOUNDRIES LTD.

ITEM CATEGORY: DUCTILE IRON MANHOLES COVERS AND FRAMES
 ITEM DESCRIPTION: FRAME WITH WATERTIGHT COVER AND LOCKED GRATING
 HINGED GRATING

MATERIAL:
 Ductile cast iron in accordance with EN124 Standards.

CHARACTERISTICS:
 ø 600 mm. clear opening.

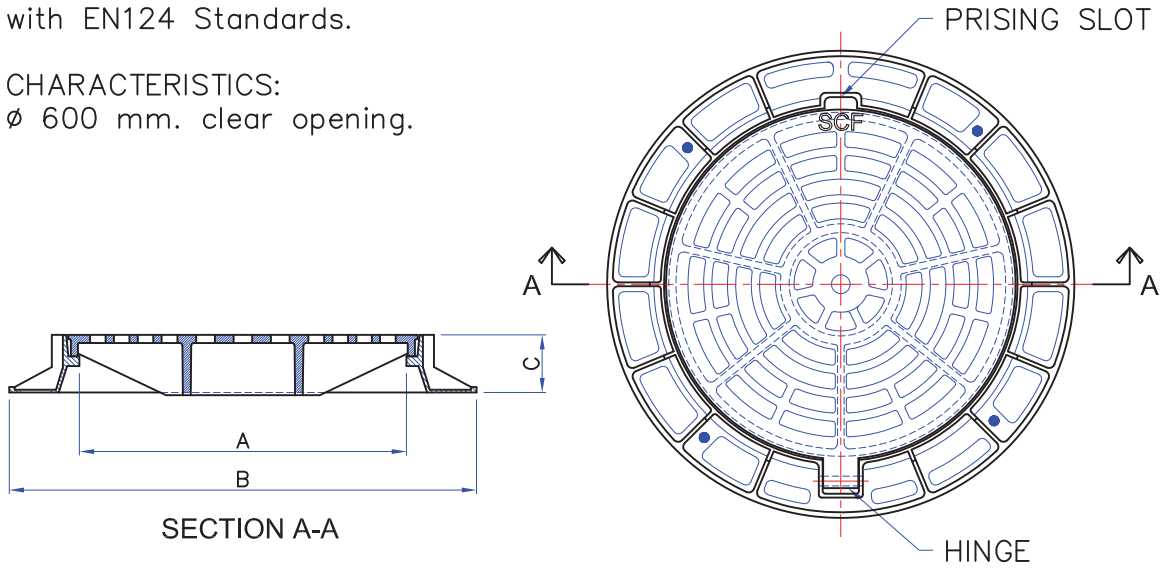

Item code	Clear Opening A(mm)	Over Base B(mm)	Depth C(mm)
DI-3	ø 600	ø 800	100
DI-4	ø 600	800 x 800	150

MATERIAL:
 Ductile cast iron in accordance with EN124 Standards.

CHARACTERISTICS:
 Hinged grating with anti-theft mechanism once installed.

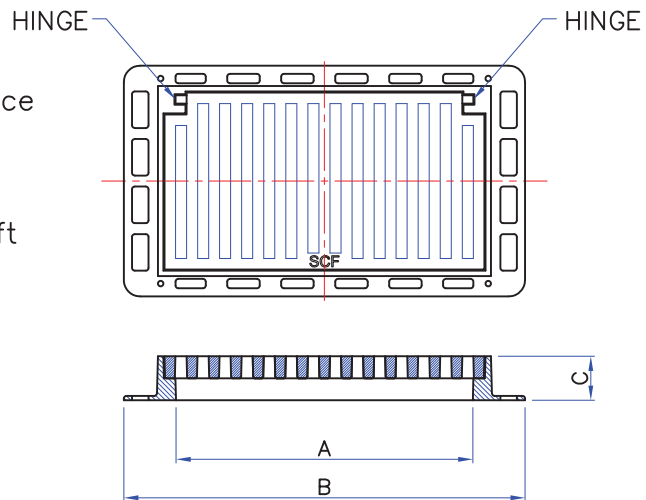

Item code	Clear Opening A(mm)	Over Base B(mm)	Depth C(mm)
DI-5	540 x 290	730 x 420	80

ALL WEIGHTS ARE SUBJECT TO ± 5%

(IF IN DOUBT, PLEASE ASK)

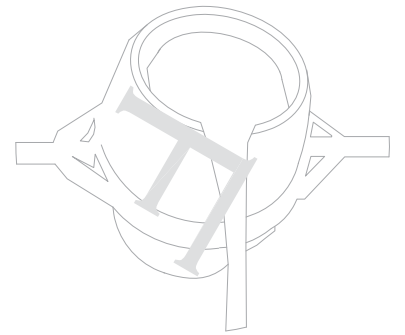
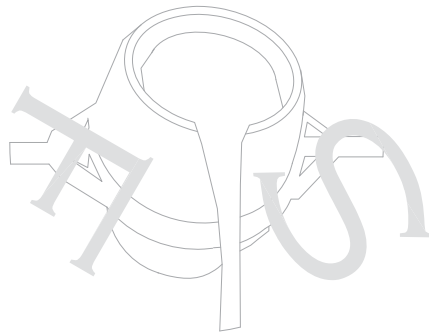
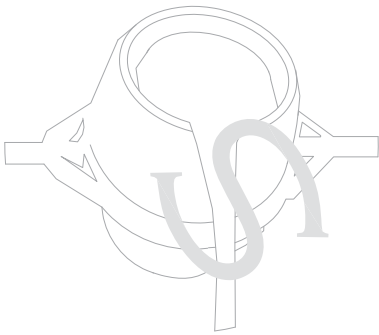
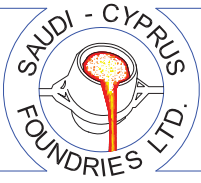

CAST METAL STEPS

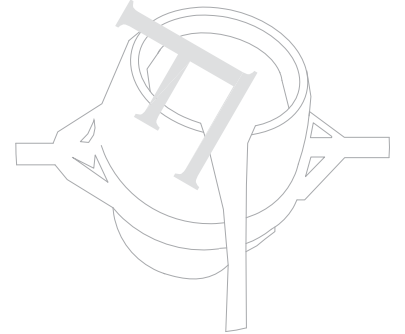
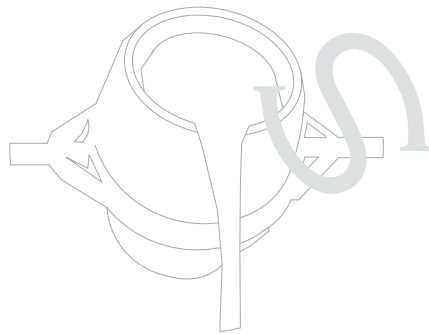
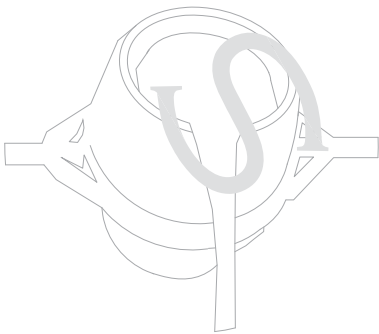
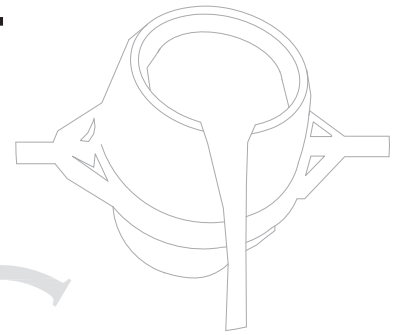
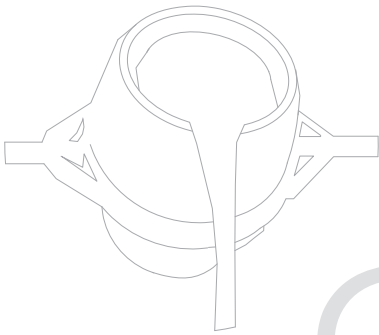

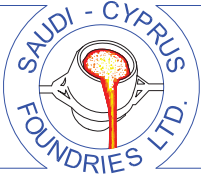

شركة المصنع السعودي القبرصي لسبك و تشكيل المعادن المحدودة
SAUDI CYPRUS FOUNDRIES LTD.

ITEM CATEGORY: CAST METAL STEPS

ITEM DESCRIPTION: U-SHAPED STEPS

Cast iron, Aluminum
 U-shaped steps.

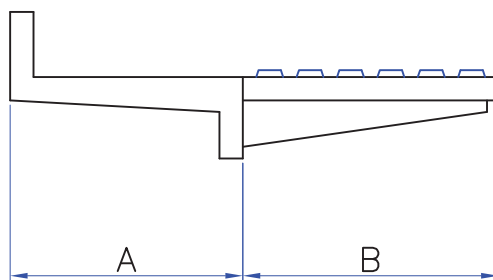
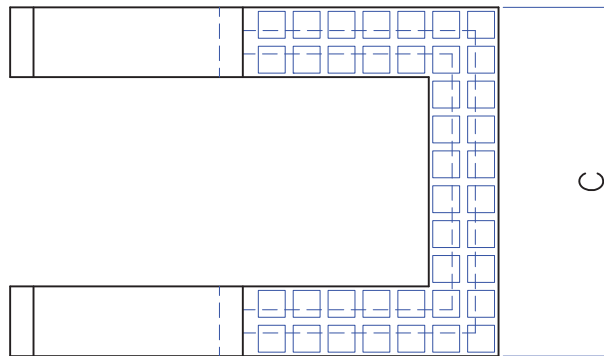

Item code	A(mm)	B(mm)	C(mm)	Material
ST-AL1	90	120	150	ALUMINUM
ST-CI2	90	120	150	CAST IRON

ALL WEIGHTS ARE SUBJECT TO $\pm 5\%$

(IF IN DOUBT, PLEASE ASK)

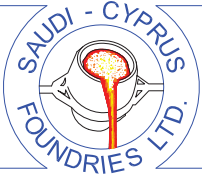

ITEM CATEGORY: CAST METAL STEPS
 ITEM DESCRIPTION: U-SHAPED STEPS WITH SCREW ENDS

Cast iron, Aluminum
 U-shaped steps
 with screw ends.

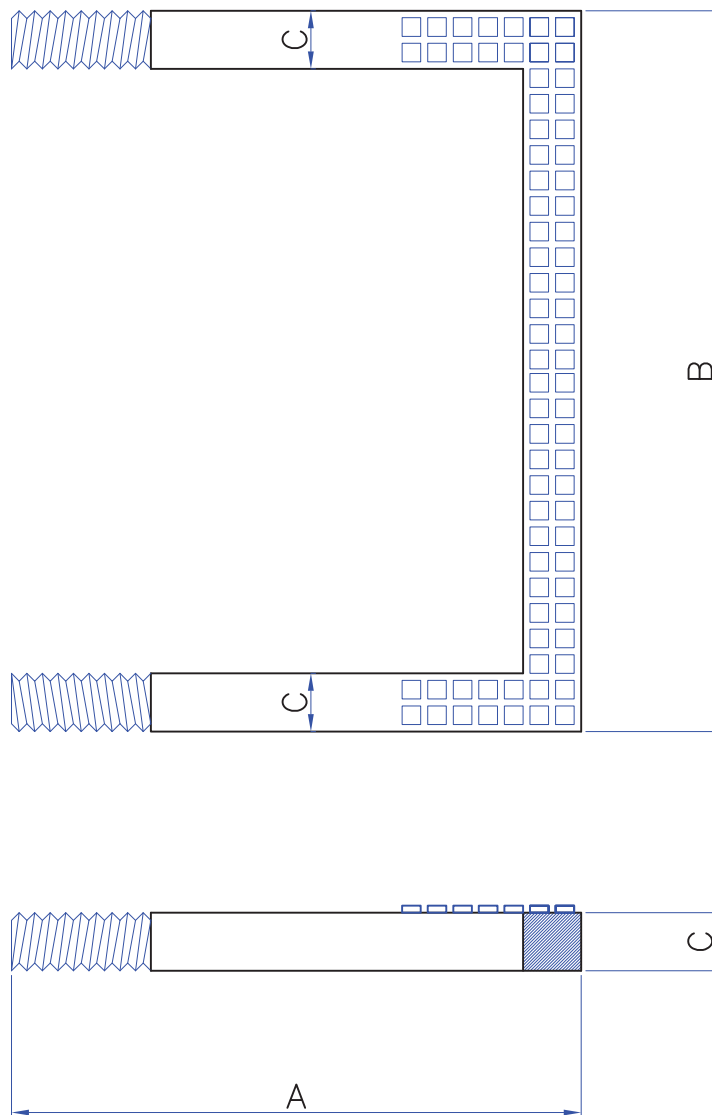

Item code	A(mm)	B(mm)	C(mm)	Material
ST-AL3	220	310	25	ALUMINUM
ST-CI4	220	310	25	CAST IRON

ALL WEIGHTS ARE SUBJECT TO $\pm 5\%$

(IF IN DOUBT, PLEASE ASK)

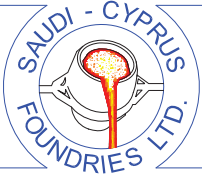

ITEM CATEGORY: CAST METAL STEPS

ITEM DESCRIPTION: U-SHAPED STEPS

Cast iron, Aluminum
 U-shaped steps.

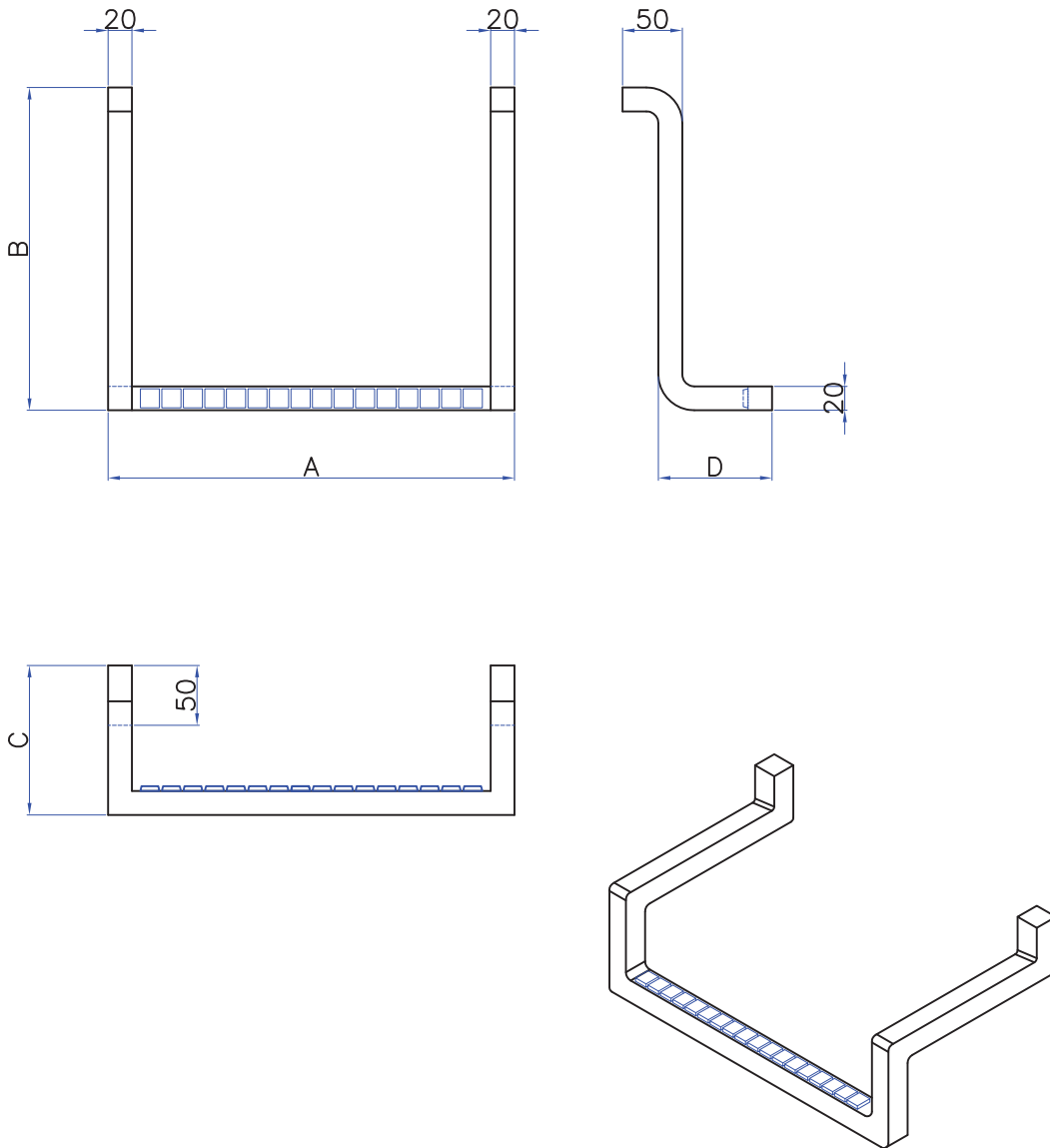

Item code	A(mm)	B(mm)	C(mm)	D(mm)	Material
ST-AL5	340	270	125	95	ALUMINUM
ST-CI6	340	270	125	95	CAST IRON
ST-AL7	340	230	125	95	ALUMINUM
ST-CI8	340	230	125	95	CAST IRON

ALL WEIGHTS ARE SUBJECT TO $\pm 5\%$

(IF IN DOUBT, PLEASE ASK)

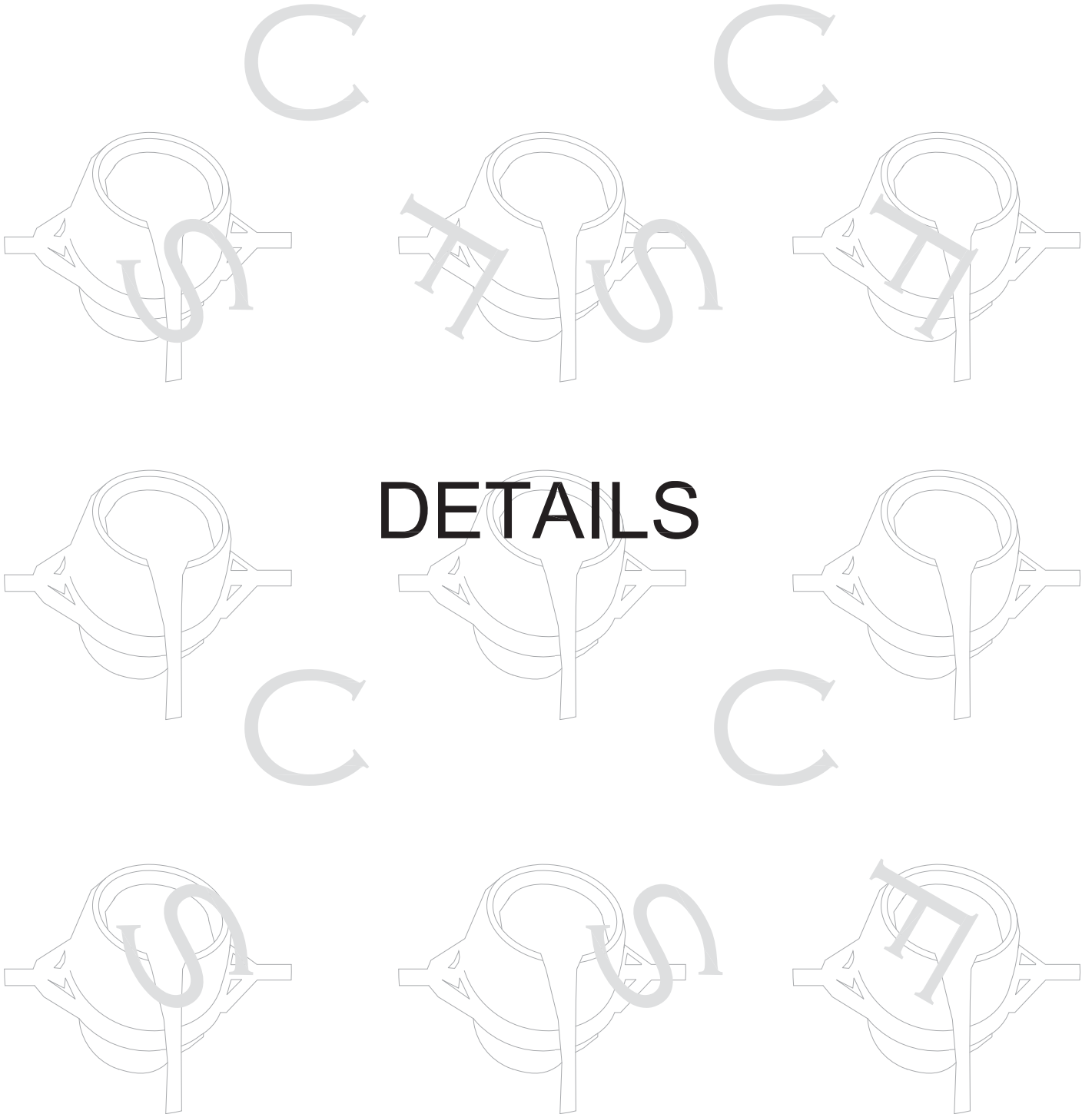
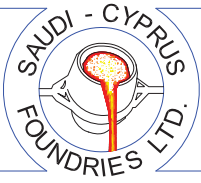

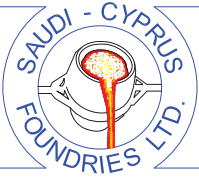

ITEM CATEGORY: DETAILS

ITEM DESCRIPTION: DOUBLE SEAL WITHOUT RUBBER AND OPEN KEYHOLES

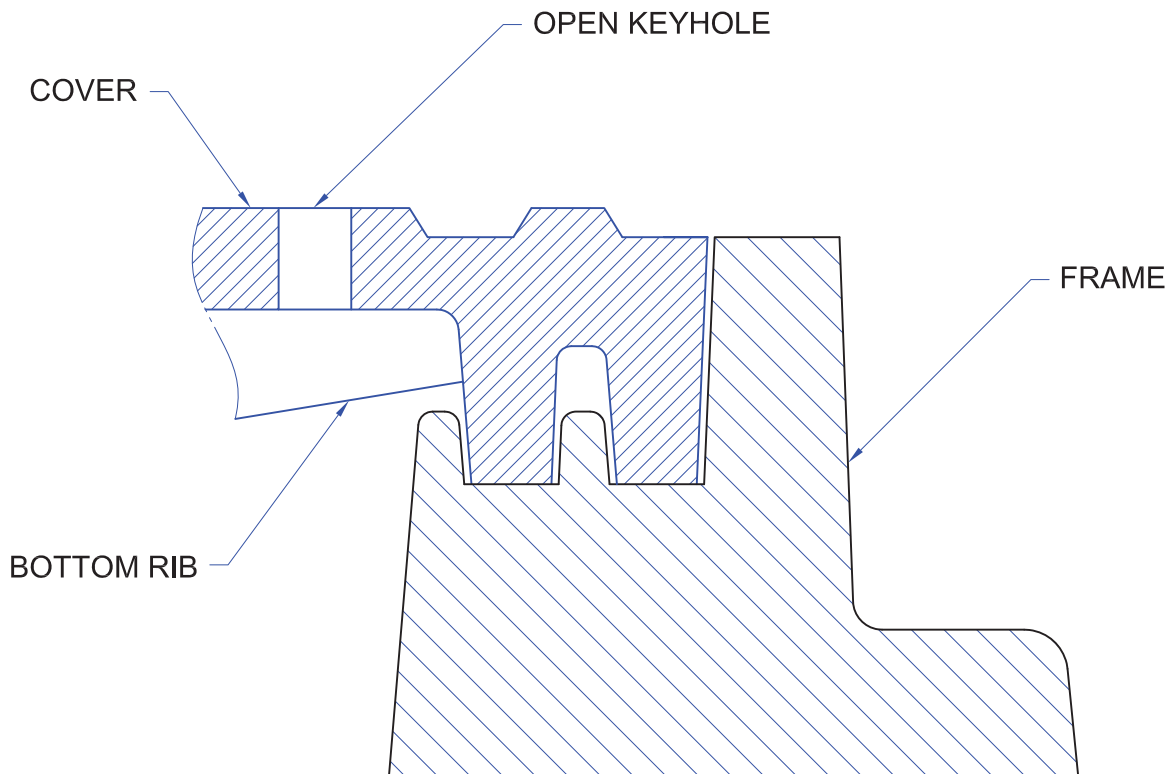

DETAILS OF DOUBLE SEAL AND OPEN KEYHOLES

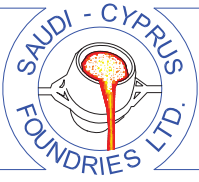

ITEM CATEGORY: DETAILS

ITEM DESCRIPTION: SINGLE SEAL WITH RUBBER

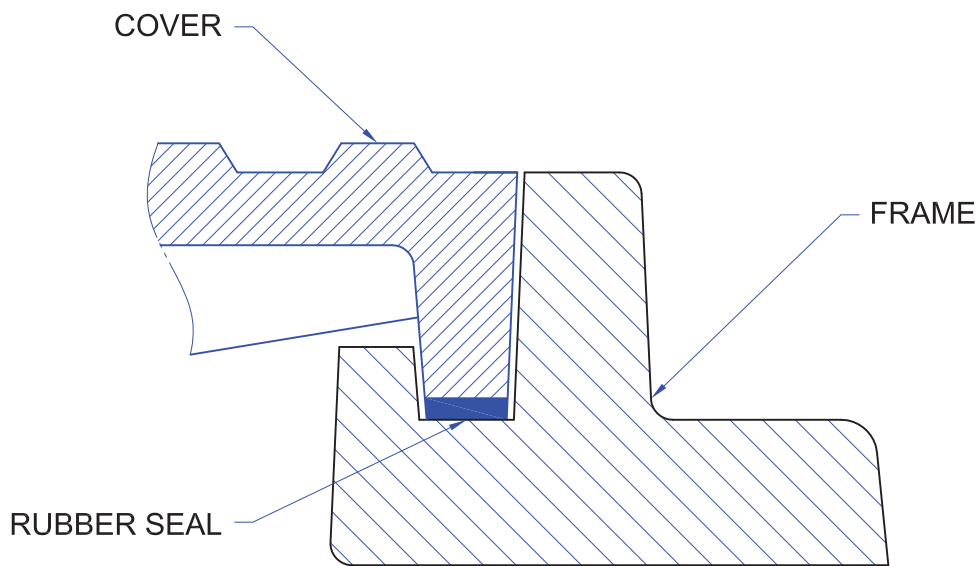

DETAILS OF SINGLE SEAL WITH RUBBER

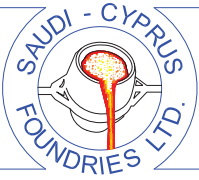

ITEM CATEGORY: DETAILS

ITEM DESCRIPTION: RUBBER SEAL ON ANGLE IRON

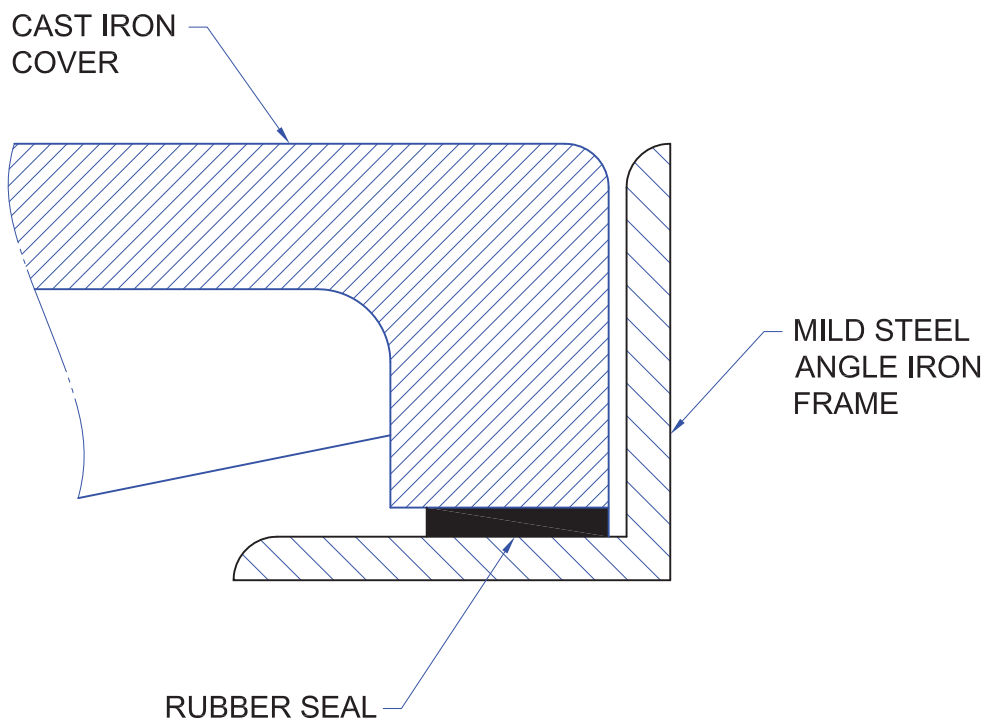

DETAILS OF RUBBER SEAL ON ANGLE IRON

ITEM CATEGORY: DETAILS

ITEM DESCRIPTION: DOUBLE SEAL WITH RUBBER AND BLIND KEYHOLES

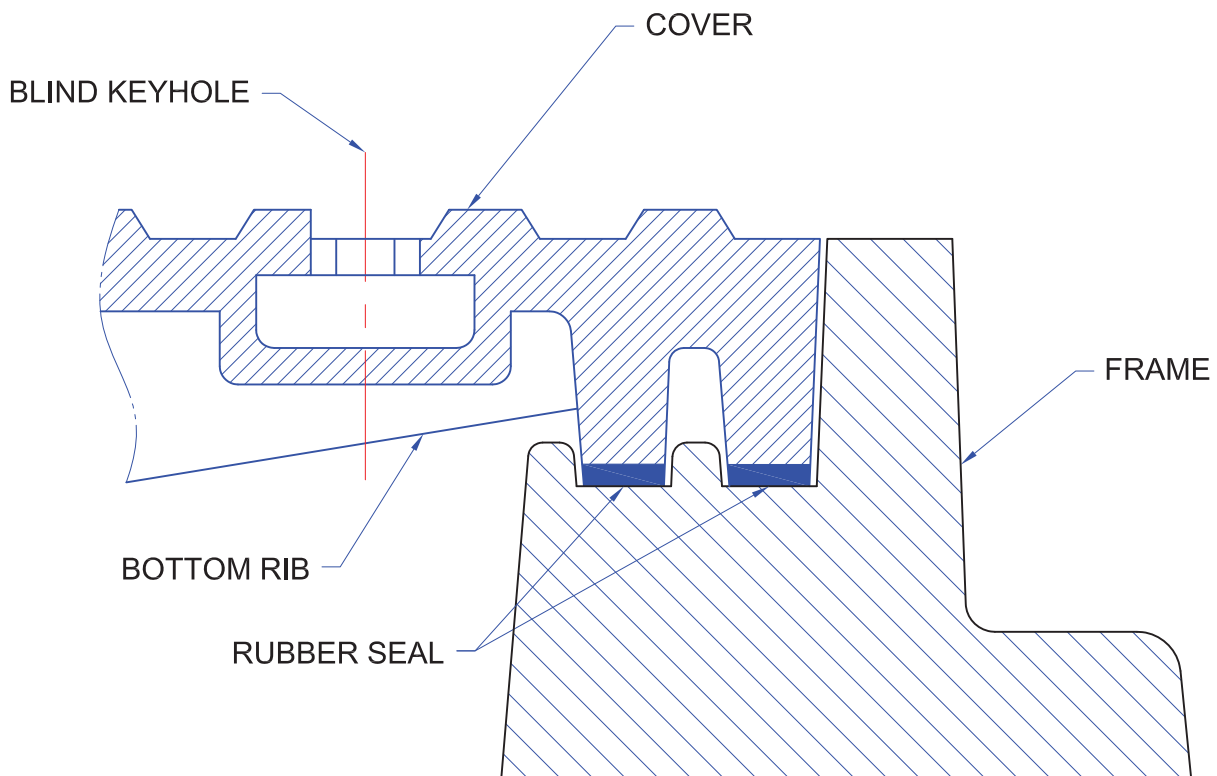

DETAILS OF DOUBLE SEAL WITH RUBBER AND BLIND KEYHOLES

ITEM CATEGORY: DETAILS

ITEM DESCRIPTION: DOUBLE SEAL WITH RUBBER AND OPEN KEYHOLES

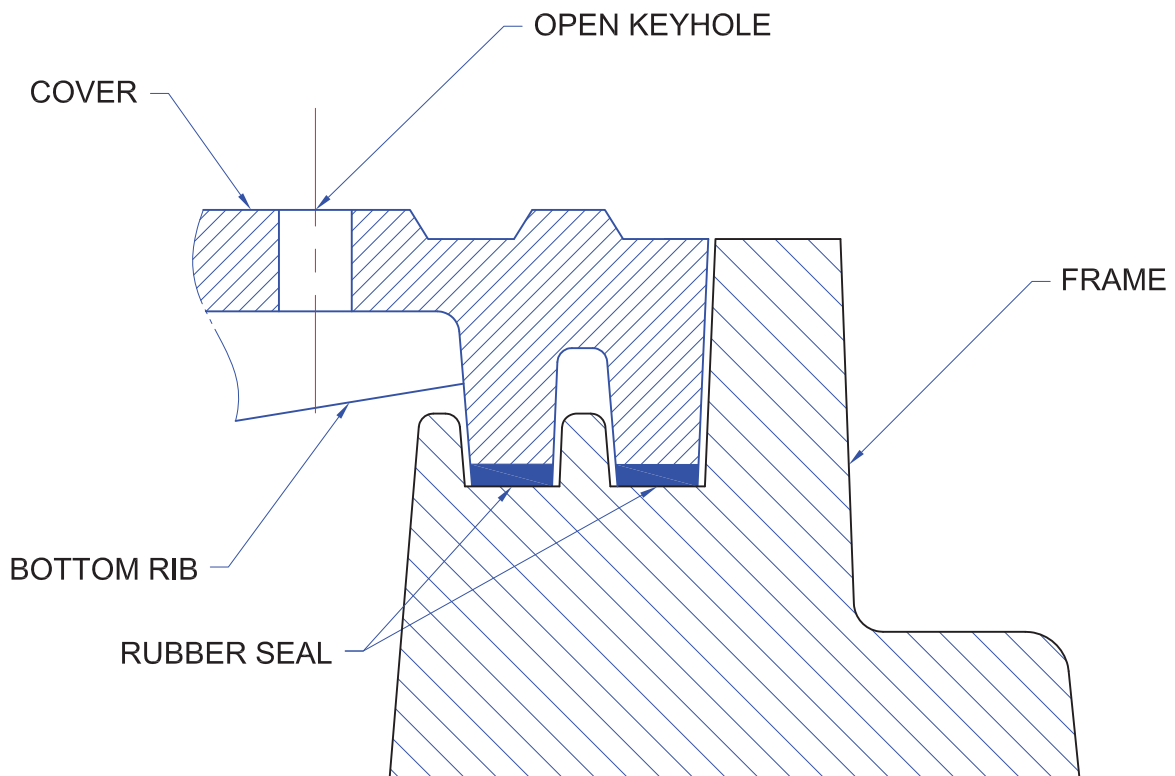

DETAILS OF DOUBLE SEAL WITH RUBBER AND OPEN KEYHOLES

ITEM CATEGORY: DETAILS

ITEM DESCRIPTION: KEYLOCK DEVICE SYSTEM

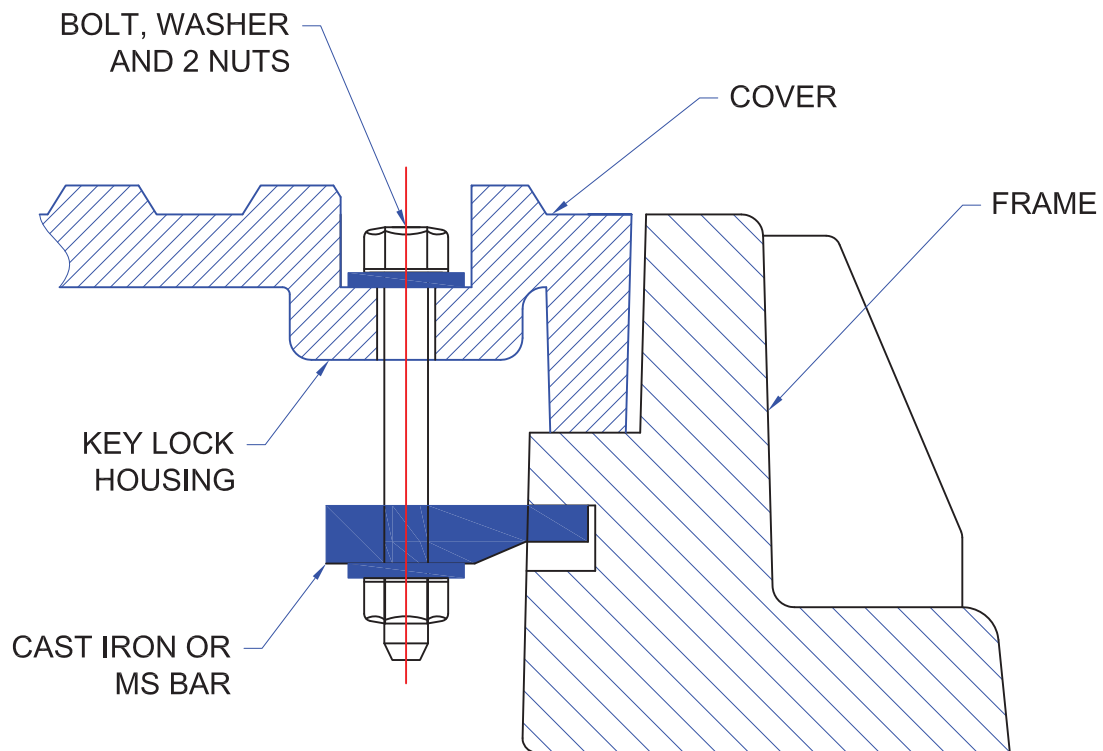

KEYLOCK DEVICE SYSTEM

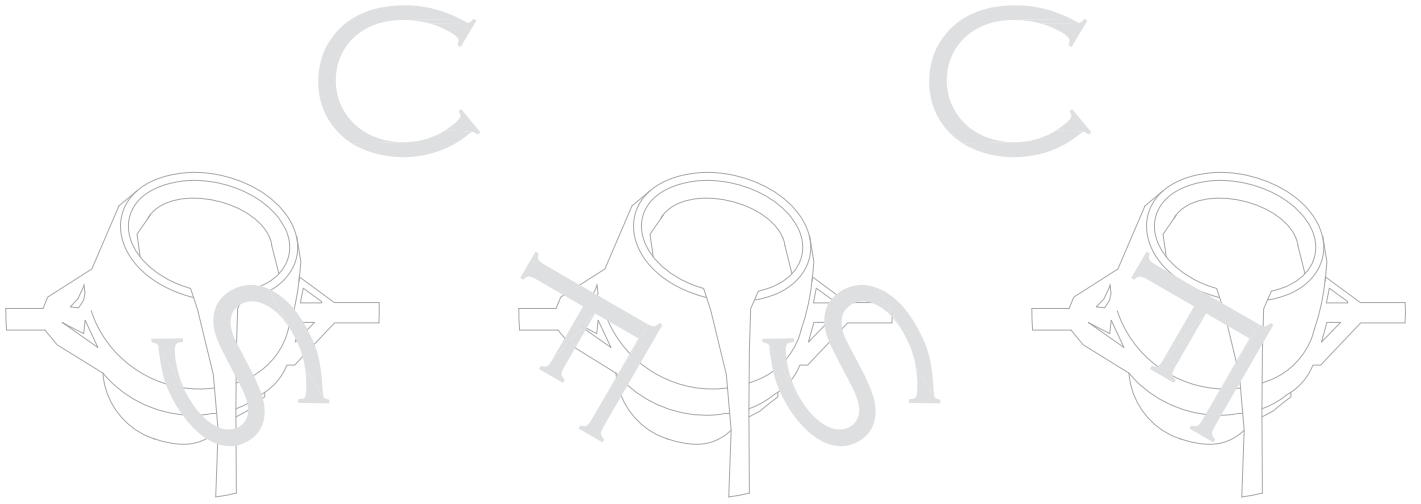
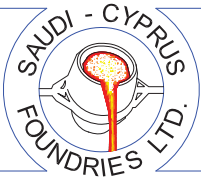

LOCATION MAP

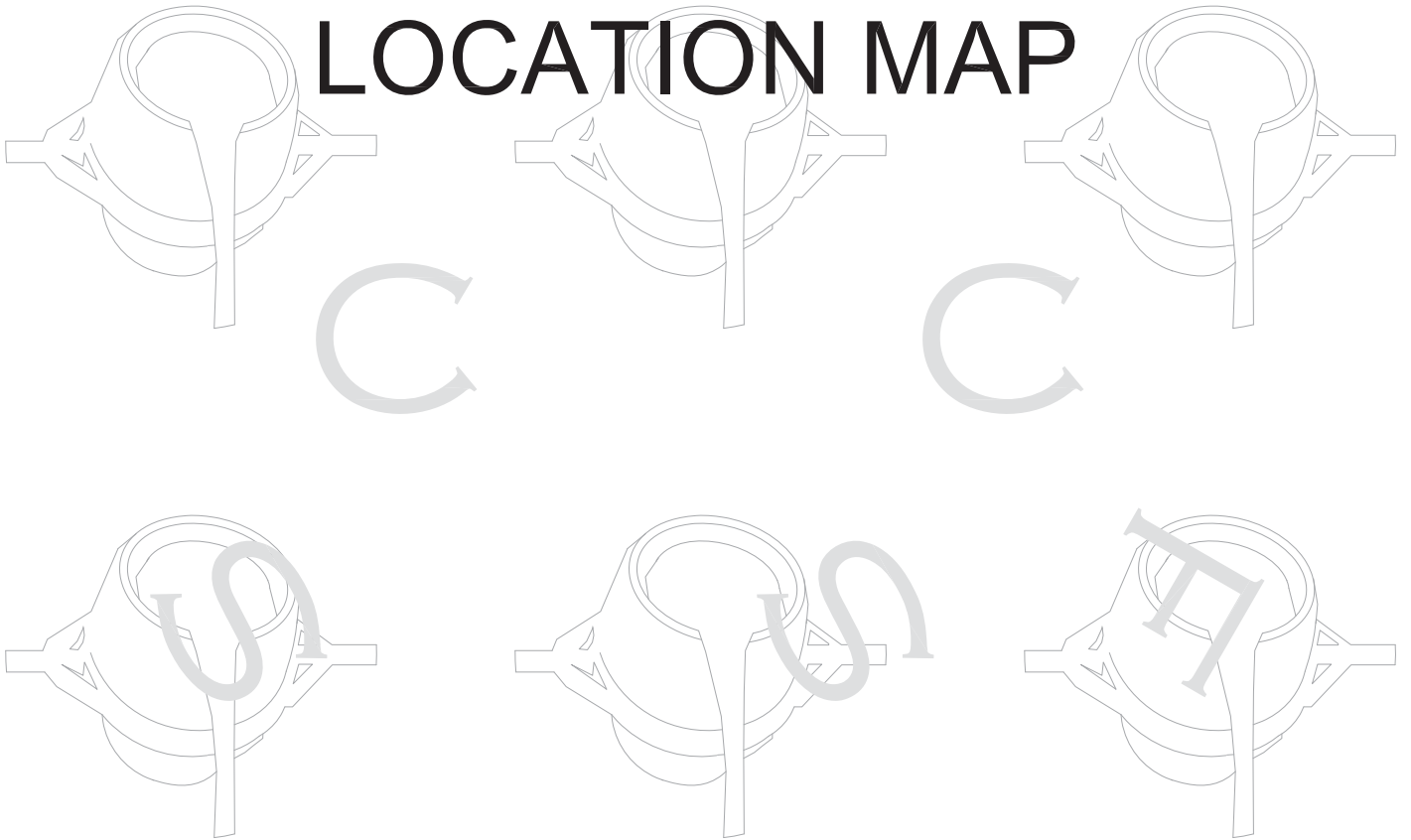

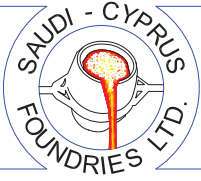

شركة المصنع السعودي القبرصي لسبك و تشكيل المعادن المحدودة SAUDI CYPRUS FOUNDRIES LTD.

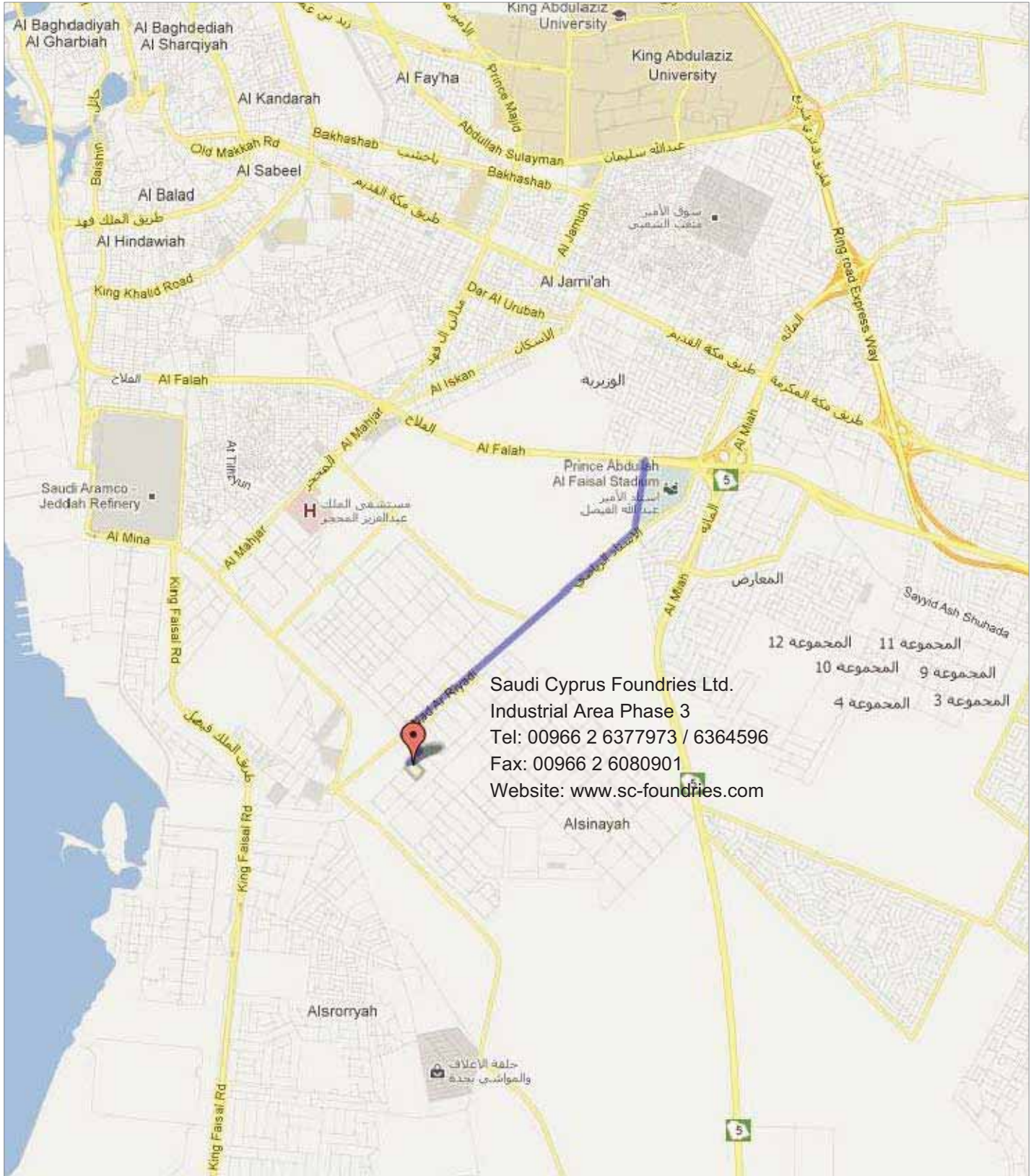

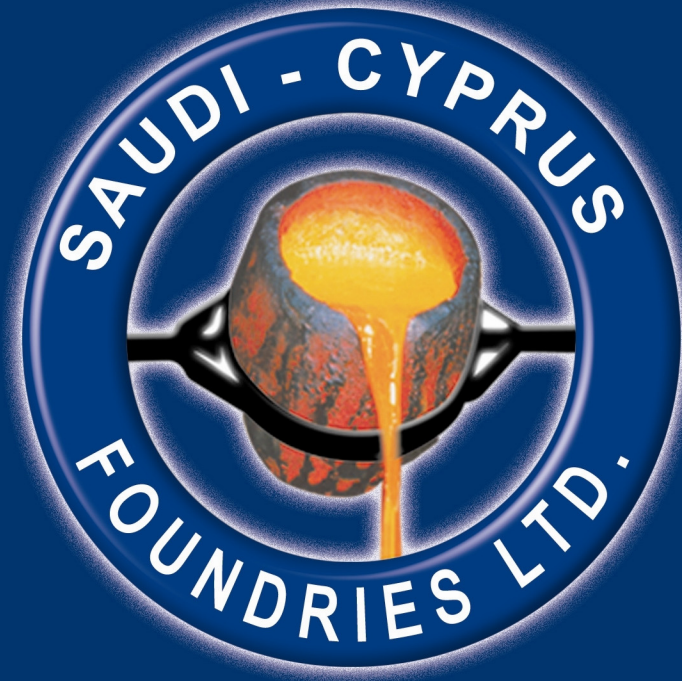

P.O. Box 977 Jeddah 21421

Jeddah - Kingdom of Saudi Arabia

Tel.: 012 - 636 4596 / 012 637 7973 Ext. 117

Telefax: 012 608 0901

ص.ب ٩٧٧ جدة ٢١٤٢١

جدة - المملكة العربية السعودية

تليفون: ٤٥٩٦ ٦٣٦ ٠١٢ / ٧٩٧٣ ٦٣٧ ٠١٢ خويلة ١١٧

تليفاكس: ٠٩٠١ ٦٠٨ ٠١٢

Email: contact@sc-foundries.com

Website: www.sc-foundries.com